

**fastAVR**



**Basic Compiler for AVR**

Created by: MICRODESIGN Bojan I.

[www.fastAVR.com](http://www.fastAVR.com)

# User Manual

# FastAVR

**Basic like Compiler**

Version 4.0.0

# User Manual

**March 2004 by MicroDesign**

## 1. Introduction



*My sincere thanks to **Michael Henning** and **Steve Childress**, for theirs assistance in writing Help and Manual.*

Welcome to **FastAVR** – the best Basic-like language compiler for the Atmel AVR family of 8-bit microprocessors!

Basic is a High Level Language, much easier to learn and understand than assembler or C.

**FastAVR Basic** is a language consisting of most of the familiar BASIC keywords but has been significantly extended with many additional very useful functions, like LCD, I2C, 1WIRE, Keyboards and many others!

**FastAVR Basic Compiler** has been specially written to fully support the programmer's needs to control the new AVR Microcontroller family!

**FastAVR Basic Compiler** allows complex operations to be expressed as short but powerful Keywords, without detailed knowledge of the CPU instruction set and internal circuit architecture. However, the processor-s data sheets remains the main source anyway.

**FastAVR Basic Compiler** hides unnecessary system details from the beginning programmer, but also provides assembler output for advanced programmers!

**FastAVR Basic Compiler** enables a faster programming and testing cycle.

**FastAVR Basic Compiler** allows the structure of the program to be expressed more clearly.

### 1.1. Compiler Operating System Compatibility

Windows 98SE  
Windows NT 4  
Windows 2000  
Windows XP

## 1.2. AVR chip supported

The most current list of AVR chips supported by the compiler is in the readme file that accompanies the installation software. Refer to Atmel's specifications or web site for descriptions. At this User's Guide release, the Atmel AVR chips supported are as follows.

2313  
2323  
2343  
2333  
4433  
4414  
8515  
4434  
8535  
8534  
ATiny13  
ATiny2313  
ATiny26  
ATmega161  
ATmega163  
ATmega103  
Atmega8 (see note 1)  
Atmega16 (see note 1)  
Atmega32 (see note 1)  
Atmega323 (see note 1)  
ATmega64 (see note 1)  
ATmega128 (see note 1)



For processors with RAM sizes of 256 bytes or less, such as the 2313, the compiler will create much smaller code sizes – typically 30% or better. This is done by generating code with addresses that are 8 rather than 16 bits – eliminating much needless code.

Most other Basic and C compilers do not provide this important optimization for small-RAM microprocessors.

**Note 1:** Compiler support for these processors requires some user-written definitions of some new register names and special coding for certain new features.

### 1.3. Development Environment

The **FastAVR** Integrated Development Environment (IDE) runs on the Microsoft Windows operating systems. The IDE includes a user friendly, language-context based editor for easily creating and altering program modules. The IDE, shown below, uses the Atmel AVR Studio software (freeware from Atmel and inexpensive and widely available in-circuit AVR chip programming hardware).

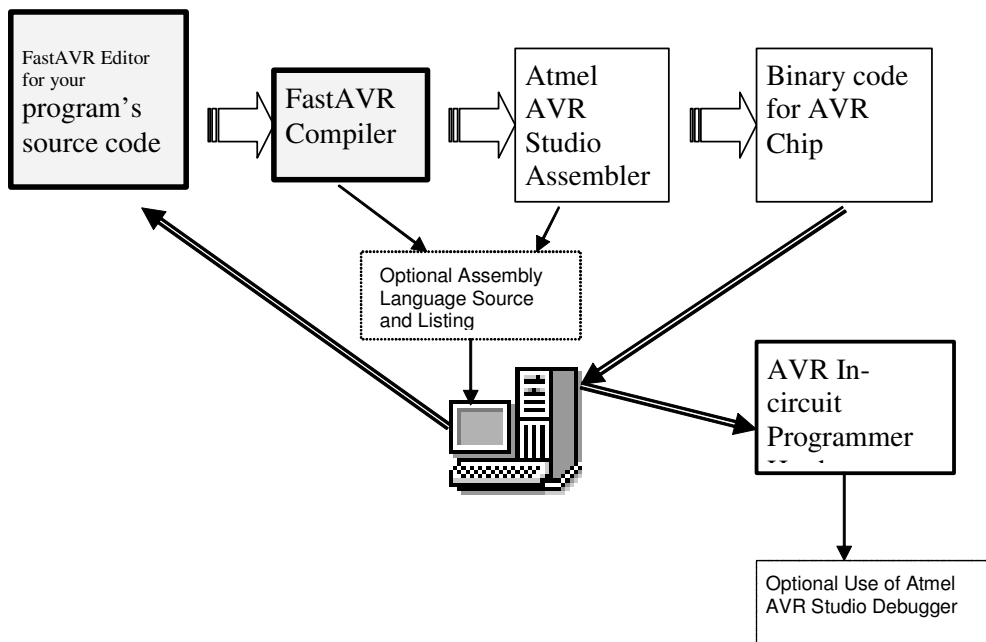

#### FastAVR Development Environment

The **FastAVR** user interface makes the use of the editor, compiler, and Atmel Studio assembler and chip programmer very easy – there is a single window to control the process. The Atmel Studio's user interface is not needed in most cases, with **FastAVR**.

The Atmel Studio software is freely available from the Atmel Web site.

There are several in-circuit programmers (ISP) for the AVR chip family. Choose one that is compatible with the ISP software you intend to use. Many of the inexpensive hardware ISP products are compatible with the ISP in the AVR Studio package. A PC parallel port interface to the ISP hardware is commonly used.

## 2. FastAVR Language Reference

### 2.1. Source code / File Data

FastAVR source code is plain text.

The editor within **FastAVR** should be used to manage source code and assure the code is properly tab-indented. Source code is displayed by the editor with color highlighting. These denote different keywords and variable types in the program. The editor supports indenting and un-indenting blocks of code.

### 2.2. Source code - Structure

Source code must be written in the following order:

1. Meta-statements (compiler directives) - where the keywords begin with "\$"
2. Declaration of Subroutines (also known as procedures), Functions or Interrupt service routines, using the DECLARE statement



Note that Subs, Functions and Interrupt service routines must be declared before they are referenced or coded.

3. Declaration of variables – scalars and arrays, using the DIM statement
4. Constants – their definitions
5. Programm body

### 2.3. Statements - multiple per line

One line of text in the source code may contain multiple statements. Each statement is separated from the next with a colon ":".

Example:

```
A = B/2: Print A
```

A statement may not be continued to a second line.

## 2.4. Comments

All text after a single quote is commentary. A code statement must be completed prior to beginning a comment. A single quote may be the first character in a line, making the entire line a comment.

```
' this is comment
```

Multi-line comments are also supported:

```
' (...
...
...
)'
```

## 2.5. Names - Symbols

User-defined constants, variable names, line labels (for GOTO) and I/O aliases (see \$DEF) must not begin with a digit and may contain the letters A-Z, a-z, the digits 0-9 and the underscore "\_". The compiler is case-insensitive, so "Abc" and "abC" and "ABC" are the same name.

Names must be no longer than 31 characters.

Examples of valid names:

```
a, A, abc, abc_123
```



Avoid use of a leading underscore "\_" to reduce the chance of conflicts with compiler-generated run-time symbols. User-defined names must differ from the reserved words in FastAVR. These include the compiler directives, AVR register names, AVR instruction names, etc.

To reduce mistakes in the use of types, some programmers use naming conventions such as:

Constants are in UPPERCASE

Variables use the first few characters of every name depict the type, such as:

```
Const strTITLE = "King Of The World"
Const STRLENMAX1 = 20
Dim strSomeName As String * STRLENMAX1
Dim SomeName As Byte ' no prefix implies Byte
Dim bSomeName As Byte ' or be explicit
Dim bitSomeName As Bit
Dim wdSomeName As Word
DimM intSomeName As Integer
Dim lngSomeName As Long
```

The capital letters help readability.

## 2.6. Types

### 2.6.1. FastAVR language General

**FastAVR** is a compiled language. Thus, all variables must be defined prior to their use.

The AVR chips use two independent memory address spaces: One for program code in ROM and one for random access, read/write memory (RAM). EEPROM storage is handled differently than program ROM or RAM. Code cannot be executed from RAM. Constants can be retrieved from program ROM using special instructions or meta-directives when the constant is declared.



The AVR chip family uses separate memory for code and for data. You must make known to the compiler which data is to go into which memory space. The compiler of course places executable code automatically. Where to store constants is the planning challenge. Programmers not accustomed to this architecture often write code assuming that constants and variables are in the same address space. In some cases, the compiler cannot detect the coding mistake. In AVR chips with EEPROM storage, decisions must be made as to which constants and infrequently changing variables are to be stored in that address space.

There are compiler directives (meta-statements) to tell **FastAVR** how constants should be stored:

- Store a constant in program memory (typically, flash ROM).
- Store a constant in program memory but copy them to RAM during program startup. With this method, the programmer accesses constants using the same coding methods as for variables, as in traditional microprocessor architectures. This costs extra storage space and program boot-up initialization code and execution time.
- Store constants or variables in EEPROM. These are read or written using run-time procedures rather than instructions to directly address EEPROM space as is done for RAM and ROM accesses.

### 2.6.2. Type Conversions

In some languages, such as Microsoft's Visual Basic, the compiler and run-time libraries do automatic type conversions, e.g., to/from string/arithmetic. This permits the programmer to be generally unconcerned about mixed types in an expression or as arguments to functions and subroutine procedures. In embedded microprocessors, this is not done for reasons of code size and speed optimization. The embedded microprocessor programmer must beware of mixing types in the same expression, and the type of the variable receiving the result of an expression. The compiler will not produce warnings in all cases. For example, adding a **FastAVR** "word" to an "Integer" with the result going to an integer or word type can produce different results, based on the programmers assumptions about signed or unsigned arithmetic.

#### Type Conversions – In Assignments

There are no compile-time type conversions built into the compiler for expressions. Any such conversions must be done by coding such in-line or via user functions.

In assignment statements such as the below, if B is a **Byte** variable and w is a **Word**:

```
b = w
```

Then b receives the low 8 bits of w.

That is, the value to the right of the "=" is converted to the type of the variable to the left of the "=".

If *w* is an **Integer** with a value of, say, -2, then *b* will become &hFE or 254.

In this assignment:

```
w = b
```

the low 8 bits of *w* receive *b*, and the high 8 bits of *w* will be zero.

In type conversions such as these, with signed numbers (integer and long), the programmer is responsible for accommodating the possibility that the sign is ignored and a multi-byte 2's complement number can become fragmented.

## Type Conversions – Implicit

In statement with an expression whose results are not assigned to a specified type, such as:

```
Print b+w
```

The run-time code will make the result be the type of the **left-most** name. This name may refer to a variable or a constant.

## Type Conversions – Bit to Byte or Word or Integer

The 0 or 1 value of the bit variable is placed in the least significant bit.

## Type Conversions – Byte or Word or Integer to Bit

A Bit variable to the left of an "=" receives the least significant bit of the value to the right of the "=".



To change a Bit variable based on the result of an expression such as  $X > 0$ , use an IF statement.

## 2.6.3. Types Arithmetic

**FastAVR** supports arithmetic (pronunciation: "arith-metic") types of variables as shown in the table, below.

Unsupported types are shown for clarity.

For signed numbers, two's complement arithmetic is used by the AVR chips and by the compiler. Thus, -1 in any signed type is all 1's and -2 has the least significant bit = 0.

Type	Size (Bytes)	Range
Bit	1 bit	0 or 1
Byte (unsigned char)	1	0-255
Integer (signed)	2	-32767 to +32767
Word (unsigned)	2	0 to 65535
Long (signed)	4	-2147483648 to +2147483647
Float	4	-2.350987E-38 to +8.507062E+37

The 32 bit signed integer type is a Long in this compiler.

Use of Longs or Float should be minimized because of the large code sizes required.

## 2.6.4. Assigning Statements

### Arithmetic variables

An arithmetic variable may receive a value from

- A constant
- A variable
- The result of a Function call returning an arithmetic type
- An arithmetic expression which may include a function

The assignment statement is of this form:

```
<variable> = <expression or constant or function>
```

Examples:

```
Gamma = 123
```

```
Gamma = X+123
```

```
Gamma = FunctionName ()
```

### String Variables

A string variable may receive a value from

- A string constant
- A string constant stored in an array (in FLASH)

The assignment statement is of this form:

```
<variable> = <expression or constant or function>
```

Examples:

```
String1 = String2
```

### I/O Register Variables, Set and Reset

A special form of assignment statement exists for AVR register bits:

```
Set <I/O bit name>
```

```
Reset <I/O bit name>
```

Where <I/O bit name> refers to an AVR register and bit.

Examples:

```
Set PORTB.0    'place a 1 in port B bit 0 (least significant bit)
```

```
Reset PORTB.7 'place a 0 in port B bit 7 (most significant bit)
```

### I/O Register Variables in General Assignment Statements

A special form of assignment statement exists for AVR register bits:

```
<varname> = <I/O bit name>
```

Example:

```
b = PORTB.1    'variable b is set to 1 or 0 depending on latched port B bit 1
```

```
b = PINB.1     'variable b is set to 1 or 0 depending on momentary state of port  
B bit 1
```

The I/O register variables may also be used in IF statements, but only where the comparison operator is the "=" operator; i.e., IF `PORTB.0 > 0` is not permitted.

---

## 2.7. Constants

### 2.7.1. Constants - Scope

Constants apply to all source statements in all files included in the compilation.

### 2.7.2. Constants- Numbers and Their Syntax

#### Decimal

Constants which are decimal (base 10) are written as follows:

Decimal positive number: <digits>

Decimal negative number: -<digits>

Where

<digits> are the digits 0-9

#### Hexadecimal (base 16)

Constants which are hexadecimal (base 16) are written as follows:

&h<digits>

Where

<digits> are the digits 0-9, A-F

Examples

`&h01` is one, `&h10` is sixteen, `&h0F` is fifteen,  
`&hFFFF` if stored into a Word or Long variable is 65535,  
`&hFFFF` if stored into a variable of type Integer is -1,

#### Binary (base 2)

Constants which are base (base 2) are written as follows:

&b<digits>

Where

<digits> is 0 or 1

Example

`&b1001` 'is nine.

### 2.7.3. Constants, Arithmetic - Declaring

Constants must be declared at the beginning of the program, before or after declaring variables. The constant's name must be unique from variables and compiler keywords.

Arithmetic constants use this syntax:

```
Const <constname> = <constant>
```

Where

<constname> is a *previously unused* valid variable name (see 6), and

<constant> is one of the following:

1. A decimal constant such as 1 or -1 or 99
2. A hexadecimal number such as &hFFFF
3. A binary number such as &b0110
4. A Scientific notation decimal constant such as  $-2.1479231E-23$
5. A *previously defined* constant's <varname>
6. A simple math expression.



An expression to the right of the "=" is permitted.

It is the programmer's responsibility to use numeric constants in a manner consistent with the storage variable's type. For example, a Byte variable cannot store a `Const x = 256`. A compile-time warning cannot be assured.

### 2.7.4. Constants, Arithmetic Arrays - Declaring

One-dimension arrays of constants may be stored in FLASH memory and accessed from flash at run time. The following syntax is used:

```
Dim <varname> As Flash <type>
```

Establishes the existence of the array. To fill (initialize) the array at compile time, the following is used, after the DIM statement.

Examples:

```
Dim abc As Flash Byte
```

... later in program ...

```
ABC = 1,2,3,4,  
5,6,7 ' Stores the binary codes for these numeric values (not ASCII)
```

Note: continues on second line due to comma after the "4".

```
Dim DigitsASCII As Flash Byte  
DigitsASCII = "1234567890" ' access with x = DigitsASCII(n)
```

The compiler will create different code to access constants in FLASH than for constants stored in RAM.

**Constants in Flash MUST be initialized at the END of Program!**

See also: Constants, String Arrays

## 2.7.5. Constants, String

### Strings in FLASH memory

Strings may be stored in FLASH memory as follows:

```
Dim String1 As Flash String
String1 = "Hello World"
```

Or

```
Const String1 = "Hello World"
```

The string is stored in FLASH memory with a null byte terminator. The name **String1** refers to that constant in FLASH. Because it is a constant, the DIM statement needed no size declaration.

**Constants in Flash MUST be initialized at the END of Program!**

## 2.7.6. Constants, String Arrays

String constants may be placed into arrays in FLASH as follows.

```
Dim Strings1 As Flash String
...
Strings1 = One, Two, Three, "Only Three"
```

This places four null-terminated strings in Flash memory with "Strings1" referring to the first element of the array of strings. The following code will access the strings

**Constants in Flash MUST be initialized at the END of Program!**

### Example 1

```
Dim s As String * 10
s = Strings1(2) ' copy from FLASH to RAM
```

### Example 2:

```
Print Strings1(n) ' where N is 0 to 3
```

## 2.8. Variables

### 2.8.1. Variables - Scope

Variables declared in the program heading are global to all source statements in all files included in the compilation. BIT variables are stored in processor registers and are thus global.

### 2.8.2. Variables, Arithmetic - Declaring

Non-dimensioned variables must be declared at the beginning of the program, after declaring constants and before code. The variable's name must be unique from constants and compiler keywords.

It is the programmer's responsibility to use variables in a manner consistent with the storage variable's type. For example, a Byte variable cannot store  $x = 256$ . A compile-time warning cannot be assured.

Variables larger than one byte are stored in successive bytes. These types are not aligned on word or long address boundaries. This is because the AVR chips address memory only as bytes.

Arithmetic variables use this syntax:

```
DIM <varname> AS <type> [AT <location>] [, ...]
```

Where

<varname> is a *previously unused* valid variable name (see 6), and

<type> is one of the following:

Type	Storage	Bit Usage
Bit	One bit	One bit
Byte (unsigned char)	One byte	8 bits
Integer (signed)	Two bytes	Two's complement, 16 bits
Word (unsigned)	Two bytes	16 bit positive number
Long (signed)	Four bytes	Two's complement, 32 bits
Float	Four bytes	IEEE
String	Len + 1	

<location> if given, is a constant defining the memory address at which the variable may be stored.

Examples:

```
Dim somevariable As Byte
Dim B As Byte
Dim This_123 As Word, delta_gamma As Bit
```



If the "AT" option is used, all subsequent variables are stored at successive locations. The use of "AT" is error prone if used after other variables have been declared and is not recommended.

### 2.8.3. Variables, Arithmetic - Run-time Type Conversions:

Some forms of type conversions are done by the compiler at run time, in storing a variable's value. Generally, the programmer should not assign a value to a variable which is from an expression or variable of a different type, or which is too large or differs in signed vs. unsigned. The following table summarizes:

Variable Type	Assignment Type	Result
Bit used)	Byte, Integer, Word or Long	Valid for all but Long (LSB used)
Byte (unsigned char)	Integer, Word or Long	Least significant byte
Integer (signed)	Word or Long	Least significant two bytes
Word (unsigned)	Word or Long	Least significant two bytes
Long (signed)	Word	Least significant two bytes
Float		

### 2.8.4. Variables, Arithmetic - Arrays

One dimension Arrays of arithmetic variables type **Byte, Word and Integer** are supported.

Syntax: DIM <varname>(n) AS <vartype> where <vartype> is as listed above.  
"n" must be a numeric or previously defined named constant

Arrays can be initialized with:

```
ArrName=(d0, d1, d2, .....)
```

or with

```
MemLoad (VarPtr(n), 4, 4, 4, 15, &hff, &hff)
```

Example:

```
Dim someBytes(aconstant) As Byte
```

It is the programmer's responsibility to declare and use array sizes so that they will fit into the available RAM.



The compiler does not create run-time error checking for array index validity. For example, the code `x = a(999)` is invalid for an AVR 2313 chip.

Do not use the same name for an array and for a non-dimensioned variable.

### 2.8.5. Variables, String

Strings in FastAVR assume 8 bit ASCII characters. Strings are null-terminated. For string constants, the compiler inserts a null. For variables, the programmer must ensure that the string's declared length allows for one extra character for the null.

String variables (see below) are declared with a fixed length.



The programmer must not permit a string variable to receive a value longer than the length of the variable, minus one. If this happens, subsequent memory storage will be overwritten and/or a string may not be null-terminated. This causes difficult to debug problems. String length limit checks are not done at run time for reasons of efficiency.

String variables are blocks of RAM into which run-time code places ASCII characters terminated by a null. They are declared as follows:

```
Dim <varname> As String *n
```

where

n is a numeric constant such as 8 or 12

This form is permitted:

```
DIM <varname> AS STRING * <ConstantName>
```

where **ConstantName** is the name of a constant.

Examples:

```
Const MAXLEN = 32
Dim LastName As String * MAXLEN
Dim FirstName As String * 16
```

In both cases, the storage allocated is one greater than the value of the constant, to make room for the terminating null.

The "\*" does not mean the same thing as it does in other languages (e.g., operating with a pointer).



For reasons of efficiency, the compiler does not generate string length checking code. The programmer must assure that a string variable's storage size is sufficient, including the necessary terminating null byte. The run-time libraries truncate a string to fit the defined size of a string variable.

## 2.8.6. Variables, String Arrays

One dimension Arrays of Strings variables are supported.

Syntax: DIM <varname>(n) AS STRING \* <ConstantName>

"n" must be a numeric or previously defined named constant

Arrays can be initialized with:

```
ArrName=(StrConst0, StrConst1, StrConst2, .....)
```

or with

```
ArrName=(StrConst)
```

to init all elements to StrConst!

Example:

```
Dim MyString(10) As String * 7 ' ten Strings seven characters each (total 8)
```

If there is only one string constant then the whole array will be initialized to this String Constant!

```
MyString=(" ") ' will init all array elements to " "
```

```
MyString=("123", "ABC", " ") ' will init first three elements
```

It is the programmer's responsibility to declare and use array sizes so that they will fit into the available RAM.



The compiler does not create run-time error checking for array index validity. For example, the code `x = a(999)` is invalid for an AVR 2313 chip.

Do not use the same name for an array and for a non-dimensioned variable.

Note also that Strings itself acts like arrays of Bytes

`s3(4)` is fifth element from String `s3` (starting with index 0).

## 2.9. Declarations - Procedures and Functions

### 2.9.1. Declaring Procedures

Procedures are like subroutines. They receive passed variables as parameters and return values only by affecting global variables.

Procedures must be declared in the program heading prior to coding the procedure itself or referencing the procedure in code.



The code for the procedure itself must appear after the entire heading section of the program.

The syntax is:

```
Declare Sub <name>()
```

Or

```
Declare Sub <name>(<parameter> As <type> [, ...])
```

Where <name> is any valid name (see 6) and matches exactly the name used in coding the procedure (a.k.a. subroutine) itself, later in the program.

And <parameter> is the **dummy name** of a variable,

*NOTE: Do not choose a dummy variable name which is the same as the name of a global variable in the program;*

And <type> is the type of the dummy variable as expected by the code for the procedure.

Type BIT cannot be passed.

The order of the parameters is fixed. The order used in the DECLARE statement must be the same order used in the actual code for the procedure.

Examples:

```
Declare Sub gamma ()
```

```
Declare Sub min(a As Integer, b As Integer)
```



Run-time type checking is not performed. If a variable of a type other than that in the DECLARE is passed, unpredictable results or branching may occur.

## 2.9.2. Declaring Functions

Functions are like procedures but return values. A function, like a variable, has a particular type.

Functions must be declared in the program heading prior to coding the procedure itself or referencing the procedure in code.



The code for the function itself must appear after the entire heading section of the program.

Function names are used to the left of an "=" in an assignment statement.

The code for the function itself must appear after the heading section of the program.

The syntax for a function is the same as for a procedure except as noted below. See 7.

```
Declare Function <name>() As <return type>
```

Or

```
Declare Sub <name>(<parameter> As <type> [,...]) As < function type >
```

Where <name> and <parameter> and <type> are as explained for DECLARE SUB,

And <function type> is the type returned by the function, as if the function were an ordinary variable.

Functions may be of type **Byte, Word, Integer, Long or Float**.



Functions of type **String** or **Bit** are not permitted.

The value returned by the function is that assigned using the function's name in the left side of an assignment statement which is within the function.

Function names are used to the left of an "=" in an assignment statement.

### 2.9.3. Declaring Interrupts

Interrupt procedures are subroutines used to process a hardware-generated interrupt.

Interrupt procedures are identical to Procedures (see 7), except:

- They must never be called from statements in the code
- They are invoked by the AVR chip's interrupt hardware

**Declare Interrupt** <interrupt cause name> ()

Where <interrupt cause name> is the symbolic name of an interrupt cause for the AVR chip targeted by the compilation.



A list of interrupt cause names is in section 11.

The parentheses after the name are necessary.

Example:

```
Declare Interrupt Ovf1 ()
```

Means that later in the code there is an interrupt procedure coded for the timer 1 overflow interrupt source.

## 2.10. Statements

### 2.10.1. Statements, Arithmetic Expressions

An arithmetic assignment statement takes the following form:

```
<varname> = <expression>
or
Print <expression> ' a special assignment to convert to a string type
```

where <expression> is  
 <name> <arithmetic operator> <name > [ ... ]

where  
 <name> is the name of an arithmetic variable or arithmetic constant  
 <arithmetic operator> is an arithmetic operator (see 9)

Parentheses may be used in expressions to control the order of operations.

Examples:

```

A = B
A = B+1
A = B/2
A = B+ (C/2) +D*E

```

## 2.10.2. Statements, String Expressions

An string assignment statement takes the following form:

```

<varname> = <string expression>
or

```

**Print** <string expression> ' a special assignment

Where <string expression> is

- A string constant
- A string variable which has received a value
- A built-in (library) string function defined later in this document. User-written functions may not return type string (or Bit).

The variable receiving the result should be large enough to store the entire result. If not, the result is truncated to make room for the automatically-inserted terminating null byte.



If the name to the right of the "=" is a string constant, or if the Print statement's argument is a string constant, then note: Special code is generated to copy the string from FLASH to RAM.

## 2.11. Program Flow

### 2.11.1. Statement, Do - Loop

The DO statement creates a loop. DO/LOOP loops may be nested. The following forms are permitted:

1. Infinite loop
 

```

DO
  <statements>
LOOP ' Only way out is a Exit Do and GoTo

```
2. Conditional loop
 

```

DO
LOOP WHILE <condition>

```

Where <condition> is an expression evaluating to true or false.

Examples:

```
WHILE x=0
WHILE x < 8
WHILE a >= b
WHILE String1 <> "ABC"
```

In either form, the statement

```
EXIT DO
```

within the loop causes the statement below the LOOP statement to be executed.

Example:

```
DO
  <statements>
  IF <condition> THEN
    EXIT DO ' cannot be on same line as THEN
  END IF
LOOP
```

As in non-looping code, interrupts may occur and execute an interrupt procedure.

### 2.11.2. Statement, While - When

The WHILE statement creates a loop, similar to DO.

The form is:

```
WHILE <condition>
  <statements>
WEND
```

The statement

```
EXIT WHILE
```

within the loop causes the statement below the WEND statement to be executed.

As in non-looping code, interrupts may occur and execute an interrupt procedure.

### 2.11.3. Statement, For - Next

The FOR statement creates a loop as in traditional BASIC. FOR/NEXT loops may be nested.

The forms are:

1. Increment by +1

```
FOR <iteration variable> = <initial value> TO <final value>
```

```

    <statements>
NEXT

```

Where <iteration variable> is a numeric variable large enough to contain the <final value>, and <initial value> is a constant or variable whose value is stored in <initial value> prior to the first iteration, and <iteration value> is incremented by one after all <statements have been executed>, and <final value> is a constant or variable whose value is compared with <iteration variable> after all <statements> are executed.

At least one iteration is assured.

## 2. Increment or decrement by arbitrary amount

```

FOR <iteration variable> = <initial value> TO <final value> STEP <delta>
    <statements>
NEXT

```

Where <delta> is a positive or negative numeric of numbers whose value is added to <iteration value>. A named constant or variable may not be used. Instead, use the DO statement.

### 2.11.4. Statement - If

In this section, the notation

<relation>

means

<expression> <relational operator> <expression>

Example of a <relation>:

A=B



Note that <expression> can be a special I/O register reference such as "PINB.2".

### Single line form

The syntax has these forms:

1. IF <relation> THEN <statement>  
Statement is executed if <relation> is true.  
Example: IF a > b THEN Print "yes"
2. IF <relation> <logical operator> <relation> THEN <statement>  
Statement is executed if all <relation> are true.  
Example: IF a > b AND a < 10 THEN Print "yes"
3. Same as above, but with additional logical operators.  
Example: IF a > b AND a < 10 OR a > 100 THEN Print "yes"

Parentheses may be used for clarity.

The ":" for multiple statements per line may not be used in the single-line IF.



The ELSE clause is not permitted in a single-line IF statement.

## Multi-line form

The syntax has these forms:

1. IF <conditional> THEN  
    <statements>  
END IF
2. IF <conditional> THEN  
    <statements>  
ELSE  
    <statements>  
END IF
3. IF <conditional> THEN  
    <statements>  
ELSEIF <conditional> THEN  
    <statements>  
END IF
4. IF <conditional> THEN  
    <statements>  
ELSEIF <conditional> THEN  
    <statements>  
ELSE  
    <statements>  
END IF

### 2.11.5. Statement - Select Case

Selects a block of statements from a list, based on the value of an expression or a variable.

In the below, the notation

<value>

means

- a variable of the same type as in the SELECT CASE statement, including type String,
- a constant of the same type as in the SELECT CASE statement, including type String,

Syntax forms:

```
SELECT CASE <variable>
CASE <value>
    <statements>
CASE <value> TO <value>
    <statements>
CASE <relational operator> <value>
    <statements>
CASE ELSE
    <statements>
```

END SELECT

The CASE ELSE may be omitted.

The keyword "TO", above, is normally used with numeric values. It is the same as `<value> <= <value>`.

If `<value>` is a string, the TO operator tests for equality.

### 2.11.6. Statement - Goto

Syntax:

GOTO <label>

Where <label> is a valid name as in variable name, and that name is the same as the name used in a label statement.

A label statement is a symbol which first in the line of code and ends with a colon:  
<name>:

where the name is not a reserved keyword

Example:

Here:

```
GOTO Here
GOTO There
```

There:

Good programming style is to use GOTO sparingly, typically to branch out of a deeply nested conditional or nested loops.



Warning: The scope of a label is global. A GOTO can be coded to jump into a SUB or FUNCTION, or out of such. This will corrupt the stack pointer management. A GOTO in a SUB or FUNCTION should reference only labels in the same SUB or FUNCTION. A GOTO outside any SUB or FUNCTION should not reference a label inside a SUB or FUNCTION. The compiler does not enforce these rules.

### 2.11.7. Statement - On X Goto

*Description:*

Jumps to one of listed line labels, depending on value of a numeric variable or numeric constant, shown here as "X". Compiles to code smaller and faster than an IF or Case statement.

*Syntax:*

On x GoTo LabelA, LabelB, LabelC [, ...]

If numeric variable x is zero, then the program continues at line label "LabelA", if 1 then to LabelB, and so on.



The programmer must ensure the validity of the variable (X in this explanation). The value must be in the range of 0 to n-1, where there are n choices in the statement. In the example, X must be in the range of 0 to 2. The line labels

**Example:**

```
DIM ABC As Byte

ABC = 1
On ABC GoTo Label0, Label1, Label2
<other code>
LabelA:
    Print "ABC was 0"
LabelB:
    Print "ABC was 1"
LabelC:
    Print "ABC was 2"
```

**2.11.8. Statement - On X Sub()***Description:*

Calls one of the listed Sub(), depending on value x. Compiles to code smaller and faster than an IF or Case statement containing Sub Calls.

This is similar to On X GOSUB lable1, label2, ... in other languages.

The action taken is the same as shown for **On X GoTo** except that the Sub() is called whereas On X GOTO does a jump, not a call. On return from the Sub, the code following the On X Sub() is executed after the Sub() returns.



The call to the Sub() must include no parameters within the parentheses.



The programmer must ensure the validity of the variable (X in this explanation). The value must be in the range of 0 to n-1, where there are n choices in the statement.

**Example:**

```
DIM ABC as Word
DECLARE SUB Foo()
DECLARE SUB Bar()
ABC = 1
DO
    On ABC Foo(), Bar()
    Print "Returned From Sub"
LOOP

SUB Foo()
    Print "ABC was 0"
END SUB

SUB Bar()
    Print "ABC was 1"
END SUB
```

## 2.12. Compiler and Limitations

**FastAVR** Basic Compiler translates your Basic source file into assembler code. The assembler file is then assembled with Atmel's free Assembler (AvrAsm32.exe). Of course, the generated assembler file can be edited with additional assembler statements and then recompiled!

### LIMITATIONS:

While testing `Bit` variables of any kind (`bit var`, `port.bit` or `var.bit`) only "=" or "<>" can be used!

```
Dim b As Bit
Dim n As Byte

If b=1 Then      ' OK
If n.5=1 Then   ' OK
If PinD.5=1 Then ' OK
If PinD.5<>1 Then ' OK

If b>0 Then     ' NOT OK
If n.5<1 Then  ' NOT OK
If PinD.5>0 Then ' NOT OK
```

Also, if user wishes to use bitwise operators with logic, bitwise must be in parentheses!

```
If (n And 1)>5 Or b=1 Then      ' OK
```

Basic itself does not have a `CAST` like C does! So if the left side of an assignment is of type "Byte" then only the lower bytes of words and/or Integers from the right side of the expression are processed!

```
Byte = Word / Byte1      'wrong result
Word1 = Word / Byte1
Byte = Word1             'correct result
```

When using an expression with the `Print` statement, result will be the same type as **first** element in expression:

```
Dim a As Byte
Dim b As Word
Dim c As Word

Print 10+(a*b)           'Byte result - 10 is byte
Print 10+(a*a)           'Byte result

c=10+(a*b)
Print c                   'Correct result
```

## 2.13. Language Specific

Basic programs are written using the `FastAVR` integrated editor, just as we would write a letter. This letter, your program, is pure ASCII text and can also be opened or edited with any simple (ASCII) editor like Window's Notepad. While writing this "letter," however, we must follow the language syntax understood by the `FastAVR` Basic Compiler. Let us start with some Basic rules, following these simple practical examples. Fortunately, Basic syntax and philosophy are quite easy to understand.

So let us start!

To make the program easier to read, It is recommend that comments be used first. For example:

```

'////////////////////////////////////
'///  FastAVR Basic Compiler for AVR
'///  First program using 4433
'///  Author:
'///  Date  :
'////////////////////////////////////

```

As can be seen the comment starts with a single quote character ( ' ), while the REM keyword is not supported (obsolete).

Later in the program, comments may be added in virtually every line to clarify a line purpose, such as:

```
Statements      ' make pin 4 of portd an output
```

Now we continue with some non-executable statements (also called Meta statements). The following three lines are absolutely necessary:

```

$Device=4433    'tells the compiler which chip we are using.
$Stack=32      'reserves the estimated number of bytes for the stack.
$Clock=8       'defines the crystal frequency in megahertz.

```

All configuration statements start with the character \$ (\$Lcd, \$I2C, \$key, \$watchdog, ...)

For other Meta statements please refer to the [Keywords](#) list.

Our next step is declaring (dimensioning) variables.

```
Dim var As Type
```

Keyword Dim reserves space for a defined variable in SRAM according to the type of variable.

Var is the variable's name. Allowed variable names may contain any alphanumeric characters that do not duplicate Keywords. Variable names are case insensitive.

**FastAVR** Basic Compiler supports the following element types:

Bit - occupies 1 bit (0 to1), located in r2 and r3 internal registers, (allowing 16 "bit variables" to be defined)

Byte - occupies 1 byte (0 to 255)

Integer - occupies 2 bytes (-32768 to +32767)

Word - occupies 2 bytes (0 to 65335)

String - an additional parameter is needed to specify the length and occupies the length+1 byte because they are terminated with a zero.

Long - occupies 4 bytes (-2147483648 to +2147483647)

Float - occupies 4 bytes (-2.350987E-38 to +8.507062E+37)

Dim var as String\*6

Var can be 6 characters long but occupies 7 bytes in SRAM. The 7th byte contains a zero for termination.

Optionally, the user can specify memory space for variables like:

```
Dim var as Xram Byte
```

var will be placed in External RAM (if available)

In addition, the location can be specified:

```
Dim var as Xram Byte at &h8100
```

var will be placed in External RAM (if available) at address &h8100.

Since I abandoned the Data and Lookup statements, a table of constants can be created in code memory (Flash) using the keyword Dim.

```
Dim TableName as Flash Byte
```

```
Dim TableName as Flash String
```

Length could be also declared, since some statements (Find) wants Length of the table.

```
Dim TableName(16) as Flash Byte
```

The table can later be initialized:

```
TableName = 11, 22, 33, 44, 55, 66,
           12, 13, 14, 15, 16, 17,
           23, 24, 25, 26, 27, 28
```

```
TableName = "sample string"
```

The Table is finished when no comma is encountered!

Access to table elements:

```
var = TableName(index)
```

Of course, index can be a complex expression or even a function call!

Generally, Tables in Flash works like an Arrays and they **MUST be initialized at the END of Program!!**

Dim declared variables are global, so they can be reached from everywhere in the program and their value is not destroyed.

We continue with declaring Subs and Functions.

```
Declare Sub NameOfSub(parameter list)
Declare Sub Test1(a As Byte, b As Word)
```

```
Declare Function NameOfFunc(parameter list) as Type
Declare Function Test2(a As Byte, b As Byte) as Byte
```

Also, Interrupt subroutines must be declared here.

```
Declare Interrupt Ovfl()
```

**This forms HEAD of PROGRAM and MUST be in this order: (!)**

1. Metastatements,
2. Dims,
3. Declarations,
4. Constants definitions,
5. All other statements.

Now we can finally start with executable statements.

Usually we first initialize the system: assign the initial value of variables and/or internal registers for needed settings, define each port pin direction, etc . . .

We continue by writing the main loop, which is a never-ending loop in most cases.

```
Do
  Body of the program (statements)
Loop
```

This loop is the heart of the program and may consist of:

- other loops
- assignments
- mathematical calculations
- keywords
- calls to subs or functions, etc..

More than one statement can be written on a line, separating each statement with a colon:

```
For n=0 To 15: Print n: Next
```

However, a single statement per line with a comment is preferable for clarity.

```
For n=0 To 15      'n will run from 0 to 15
  Print n          'output n to serial port
Next
```

Many expressions are supported in `FastAVR`. From very basic assignments like:

```
a=5
```

To more complex like:

```
a=(b+12)*c-3*d
```

`FastAVR` Basic Compiler performs all math operations in full hierarchal order. This means there is precedence to the operators. Multiplication and division are performed before addition and subtractions. As an example, to ensure the operations are carried out in the order needed, use parentheses to group the operations.

Even calls to system and user functions can be factors in expressions:

```
a=5*Test(15)+Adc8(3)
```

Where `Test` is your function called with parameter 15 and `Adc8(3)` is a system function that returns an 8bit value as a result of the analog measurement on channel 3.

#### List of mathematical operators:

```
+ plus sign
- minus sign
* asterisk (multiplication symbol)
/ slash (division symbol)
Mod modulus operator
```

#### List of relational operators:

```
= equality
<> inequality
<= less than or equal
>= greater than or equal
< less than
> greater than
```

#### List of logical operators:

```
And conjunction
Or disjunction
```

#### List of boolean operators:

```
And, & boolean conjunction, bitwise and
Or, | boolean disjunction, bitwise or
Xor, ^ boolean Xor
Not boolean complement
```

#### Other operators also have special meanings, such as:

```
" double quotation as string delimiters
, comma as a parameter separator
. period for ports or variable bit delimiters
; semicolon is used when more than one parameter is used (i.e., Print a; b; c)
' single quotation mark starts a comment
```

Numeric constants can be in decimal format:

```
a=33
```

in hexadecimal:

```
a=&h21 'dec 33
```

or even in bynary:

```
a=&b00100001 'dec 33
```

A Label can be used as a line identifier. Label is an alphanumeric combination ending with a colon.

```
If a=0 Then
    Goto ExitLabel
End If
```

Other statements

```
ExitLabel:          'this is a Label
```

After the main loop we write all used and previously declared subs and functions, including interrupt subroutines.

The subroutine itself starts with the keyword Sub or Function, followed by the name and parameter list (if one exists)

```
Sub Test1(a As Byte, b As Word)
Function Test2(a As Byte, b As Byte) as Byte
```

Parameter list must be identical to the declaration of the sub!

With the keyword Local we can declare local variables.

```
Local var as Type
```

Bits, Strings and Arrays are always Global!

The use and lifetime of local variables are limited to this subroutine.

The rules for Type are the same as for the Dim.

The body of Sub or Function is a complete program needed to solve a particular problem.

The Function can return a value using the keyword Return.

**If you have serious trouble in programming, especially if in doubt about the compiled results, please email source files to the mailing list for support!**

## FastAVR HINTS!

All internal registers can be accessed direct from basic:

```
XDIV = &h05          'changing clock for Mega
MCUCR = MCUCR or &h38 'enter powerdown mode
```

```
Dim Str_0 As String*15
Dim Str_1 As String*15
Dim Str_2 As String*15
Dim Str_3 As String*15
Dim s As String*15      ' working string
Dim n As Byte
```

```
MemCopy(16, Str_0+16*n, s) ' copies n-th string from Str_0 into string s (acts like Array of Strings!)
```

```
Str_2="FastAVR"
n=Str_2(4)      ' n=65 Strings acts like Arrays - elements are accessible also by index
```

Happy programming!

## 2.14. Interrupts

All AVR interrupts are supported by FastAVR!

```
Interrupt Ovf1(), Save All
```

Interrupt service routines are just like normal subroutines. Of course, instead of using the keyword Sub we will use Interrupt. The table of short names listed below may be used for Interrupt names!

Very important is the Save x directive. Save x determines how many registers will be saved before calling the interrupt. This depends on what variables are used in the routine.

Save 0, will save SREG only, could be omitted,

Save 1, will save SREG, zl and zh only.

Save 2, as Save 0 plus r24 and r25

Save 3, as Save 1 plus r0, r1, xl and xh

Save 4, as Save 2 plus r0, r1, r20, r21, r22, r23, xl and xh

Save All will save SREG and all registers from r0 to r5 and r19 to r31

When the Interrupt routine is more complex, use Save 2, Save 3 or Save All.

```
'////////////////////////////////////
Interrupt Ovf1()   'simple routine, no save
Timer1=&h7000     'reloads timer1 for 10ms
Toggle PortB.2   'toggles portb.2
End Interrupt
```

When user dont know about using Save, start with All and then try the minor versions!

Here is a list of available Interrupts

```
Int   Int Type for 2313
INT0  External Interrupt0
INT1  External Interrupt1
ICP1  Input Capture1 Interrupt
OC1   Output Compare1 Interrupt
OVF1  Overflow1 Interrupt
OVF0  Overflow0 Interrupt
URXC  UART Receive Complete Interrupt
UDRE  UART Data Register Empty Interrupt
UTXC  UART Transmit Complete Interrupt
ACI   Analog Comparator Interrupt
```

```
Int   Int Type for 4433
INT0  External Interrupt0
INT1  External Interrupt1
ICP1  Input Capture1 Interrupt
OC1A  Output Compare1A Interrupt
OVF1  Overflow1 Interrupt
OVF0  Overflow0 Interrupt
SPI   SPI Interrupt
URXC  UART Receive Complete Interrupt
UDRE  UART Data Register Empty Interrupt
UTXC  UART Transmit Complete Interrupt
ADCC  ADC Interrupt
ERDY  EEPROM Interrupt
ACI   Analog Comparator Interrupt
```

```
Int   Int Type for 8515
INT0  External Interrupt0
INT1  External Interrupt1
ICP1  Input Capture1 Interrupt
```

---

```

OC1A  Output Compare1A Interrupt
OC1B  Output Compare1B Interrupt
OVF1  Overflow1 Interrupt
OVF0  Overflow0 Interrupt
SPI   SPI Interrupt
URXC  UART Receive Complete Interrupt
UDRE  UART Data Register Empty Interrupt
UTXC  UART Transmit Complete Interrupt
ACI   Analog Comparator Interrupt

```

Int    Int Type for 8535

```

INT0  External Interrupt0
INT1  External Interrupt1
OC2   Timer2 Compare Interrupt
OVF2  Overflow2 Interrupt
ICP1  Input Capture1 Interrupt
OC1A  Output Compare1A Interrupt
OC1B  Output Compare1B Interrupt
OVF1  Overflow1 Interrupt
OVF0  Overflow0 Interrupt
SPI   SPI Interrupt
URXC  UART Receive Complete Interrupt
UDRE  UART Data Register Empty Interrupt
UTXC  UART Transmit Complete Interrupt
ADCC  ADC Conversion Complete Handle
ERDY  EEPROM Write Complete Handle
ACI   Analog Comparator Interrupt

```

Int    Int Type for ATmega103

```

INT0  External Interrupt0
INT1  External Interrupt1
INT2  External Interrupt2
INT3  External Interrupt3
INT4  External Interrupt4
INT5  External Interrupt5
INT6  External Interrupt6
INT7  External Interrupt7
OC2   Output Compare2 Interrupt
OVF2  Overflow2 Interrupt
ICP1  Input Capture1 Interrupt
OC1A  Output Compare1A Interrupt
OC1B  Output Compare1B Interrupt
OVF1  Overflow1 Interrupt
OC0   Output Compare0 Interrupt
OVF0  Overflow0 Interrupt
SPI   SPI Interrupt
URXC  UART Receive Complete Interrupt
UDRE  UART Data Register Empty Interrupt
UTXC  UART Transmit Complete Interrupt
ADCC  ADC Conversion Complete Handle
EEWR  EEPROM Write Complete Handle
ACI   Analog Comparator Interrupt

```

Int    Int Type for ATmega8

```

INT0  External Interrupt0
INT1  External Interrupt1
OC2   Output Compare2 Interrupt
OVF2  Overflow2 Interrupt
ICP1  Input Capture1 Interrupt
OC1A  Output Compare1A Interrupt
OC1B  Output Compare1B Interrupt
OVF1  Overflow1 Interrupt
OVF0  Overflow0 Interrupt
SPI   SPI Interrupt

```

---

---

URXC	UART Receive Complete Interrupt
UDRE	UART Data Register Empty Interrupt
UTXC	UART Transmit Complete Interrupt
ADCC	ADC Conversion Complete Handle
ERDY	EEPROM Write Complete Handle
ACI	Analog Comparator Interrupt
TWI	Two wire interface Interrupt
SPM	Store Program Memory Ready Interrupt

Int    Int Type for ATmega16

INT0	External Interrupt0
INT1	External Interrupt1
OC2	Output Compare2 Interrupt
OVF2	Overflow2 Interrupt
ICP1	Input Capture1 Interrupt
OC1A	Output Compare1A Interrupt
OC1B	Output Compare1B Interrupt
OVF1	Overflow1 Interrupt
OVF0	Overflow0 Interrupt
SPI	SPI Interrupt
URXC	UART Receive Complete Interrupt
UDRE	UART Data Register Empty Interrupt
UTXC	UART Transmit Complete Interrupt
ADCC	ADC Conversion Complete Handle
ERDY	EEPROM Write Complete Handle
ACI	Analog Comparator Interrupt
TWI	Two wire interface Interrupt
INT2	External Interrupt2
OC0	Output Compare0 Interrupt
SPMR	Store Program Memory Ready Interrupt

Int    Int Type for ATmega323

INT0	External Interrupt0
INT1	External Interrupt1
INT2	External Interrupt2
OC2	Output Compare2 Interrupt
OVF2	Overflow2 Interrupt
ICP1	Input Capture1 Interrupt
OC1A	Output Compare1A Interrupt
OC1B	Output Compare1B Interrupt
OVF1	Overflow1 Interrupt
OC0	Output Compare0 Interrupt
OVF0	Overflow0 Interrupt
SPI	SPI Interrupt
URXC	UART Receive Complete Interrupt
UDRE	UART Data Register Empty Interrupt
UTXC	UART Transmit Complete Interrupt
ADCC	ADC Conversion Complete Handle
ERDY	EEPROM Write Complete Handle
ACI	Analog Comparator Interrupt
TWSI	Two wire interface Interrupt
SPMR	Store Program Memory Ready Interrupt

Int    Int Type for ATmega128

INT0	External Interrupt0
INT1	External Interrupt1
INT2	External Interrupt2
INT3	External Interrupt3
INT4	External Interrupt4
INT5	External Interrupt5
INT6	External Interrupt6
INT7	External Interrupt7
OC2	Output Compare2 Interrupt
OVF2	Overflow2 Interrupt

```

ICP1   Input Capture1 Interrupt
OC1A   Output Compare1A Interrupt
OC1B   Output Compare1B Interrupt
OVF1   Overflow1 Interrupt
OC0    Output Compare0 Interrupt
OVF0   Overflow0 Interrupt
SPI    SPI Interrupt
URXC0  UART0 Receive Complete Interrupt
UDRE0  UART0 Data Register Empty Interrupt
UTXC0  UART0 Transmit Complete Interrupt
ADCC   ADC Conversion Complete Handle
ERDY   EEPROM Write Complete Handle
ACI    Analog Comparator Interrupt
OC1C   Output Compare1C Interrupt
ICP3   Input Capture3 Interrupt
OC3A   Output Compare3A Interrupt
OC3B   Output Compare3B Interrupt
OC3C   Output Compare3C Interrupt
OVF3   Overflow3 Interrupt
URXC1  UART1 Receive Complete Interrupt
UDRE1  UART1 Data Register Empty Interrupt
UTXC1  UART1 Transmit Complete Interrupt
TWI    Two wire interface Interrupt
SPMR   Store Program Memory Ready Interrupt

```

Devices not listed have the same interrupt names!

## 2.15. Outputs

**FastAVR Basic Compiler** compiles the Basic source file in the currently active editor window by pressing the RUN button! An assembler source file will be generated if no errors are encountered! Then Atmel's free Assembler (AvrAsm.exe) is called to generate an executable file in standard Intel Hex format! Also, Lst and Obj files are generated at the same time! The Obj file can be loaded directly into Atmel's free debugger-simulator AvrStudio!

```
Test.bas ----> Test.asm -> Test.hex, Test.obj and Test.eep (If InitEE is used!)
```

If the compiler is run while an Assembler window is active then only the Assembler will be called!

## 2.16. Memory Usage

With every declared variable, space is reserved in internal SRAM. The available SRAM memory depends on the chip, from 64bytes in ATiny22 to 4k in ATmega103. Except for the always needed stack space, no SRAMs<sup>20</sup> is used by the compiler.

In addition to SRAM, AVR also has a register file from 0 to 31. These are the Compilers working space.

```
Dim b As Bit will occupy one bit from R3 and R4 internal registers! No SRAM locations are needed!
Dim n As Byte will occupy one byte, starting at &h60 in SRAM.
```

```

Dim i As Integer occupies two bytes, next to variable n at &h61 and &h62
Dim w As Word occupies two bytes, next to variable i at &h61 and &h62
Dim s As String*5 will occupy six(6) bytes, five for variable s and one for the string terminator "zero". In this
case s starts after variable w in position &h63.
Dim x As Long occupies four bytes.
Dim f As Float occupies four bytes.

```

Because the entire AVR family are 8-bit microcontrollers the most efficient code is obtained by using variables of type Byte.

**FastAVR** uses two software stacks. The first one for temporary storage and for return addresses while calling Subroutines or Functions. This stack starts at the end of SRAM and grows downward. The second stack is used to store Local variables and variables that are passed to subroutines. This stack is defined by the programmer with the Meta Statement:

```
$stack=20.
```

This means that the stack will start 20 bytes below the top of SRAM and will also grow downward!

Each Local or passed variable to a Sub or Function uses stack.

When using conversion routines that convert a number to a string, the compiler will need additional SRAM space starting from the second stack UP. This is also true when Strings or StringsConstants are passed into Subs or Functions! Sometimes this can overlap the first stack, so some attention will be needed!

With some devices like the 8515, external memory may be added. However, because the XRAM can only start after the SRAM, which is at &H0260, the lower memory locations of the XRAM will not be used.

Most AVR chips have internal EEPROM on board. This EEPROM can be used to store and retrieve infrequently used data.

With **FastAVR**, access to this space is easy using `WriteEE` and `ReadEE` statements!  
Note that each address can only be written a maximum of 100,000 times!

Numeric and String Constants do not use any SRAM, they are in code (flash)!

## 2.17. Assembler Programming

Assembler code may be added at any time. However, assembler programming should not be necessary since **FastAVR** will probably generate smaller code than can be done in assembler!

Also, the generated assembler file can be edited and recompiled to fine tune the whole system!

All variables are reachable from assembler, like:

```

$Asm
    sts    tip,z1
    lds    r24,tip
$EndAsm

```

tip is a global variable!

## 3. FastAVR IDE

### 3.1. Editor

The Editor is the main part of the IDE. This is where your program appears under your fingers! Here is where you spend most of your development time! So the editor should be something very useful and friendly.

#### Some features and benefits:

- very fast syntax highlighting
- line numbers can be in decimal, hex or binary format
- bookmarks, Ctrl-F2 for mark, F2 to switch between bookmarks
- horizontal and/or vertical split bars of same file (drag from left-down and/or upper-right scroll bars),

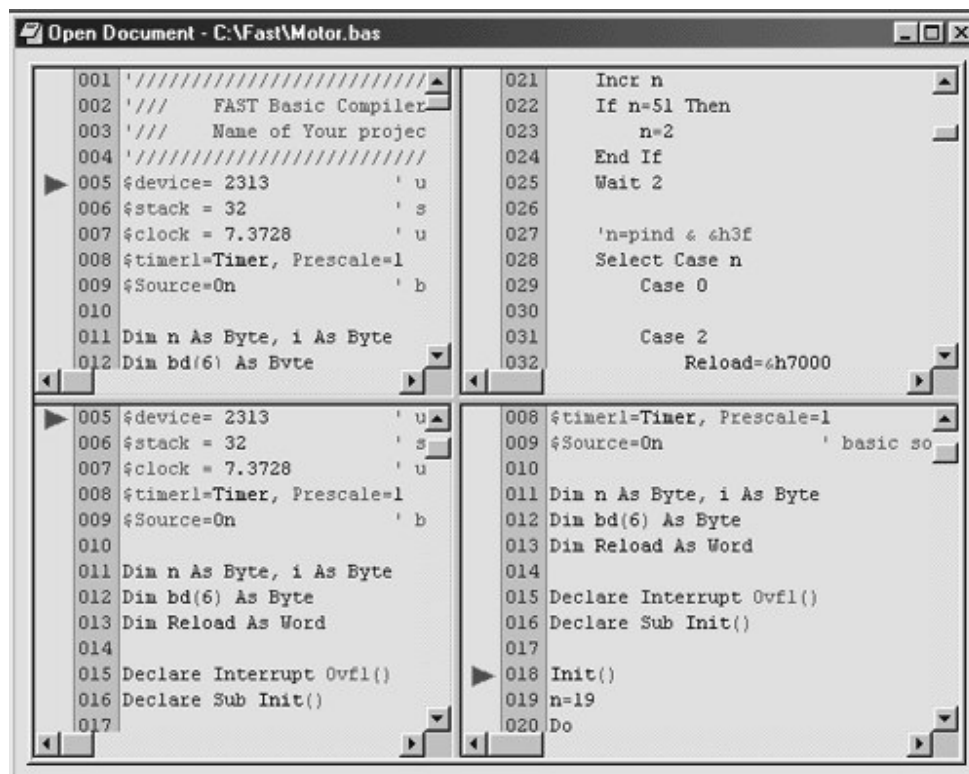

- editor properties window with right-click on editor screen:



- fully configurable keyboard commands
- double click on word to select and enable Find or Replace
- Find and Replace commands inside right-click on editor screen
- automatic reload of last edited or compiled file
- and many more...

## 3.2. IDE

Integrated Development Environment is your working desktop!  
 With easy-to-use menus, files and windows can be easily manipulated.  
 Everything needed during the development process can be found in the ToolBar.  
 Buttons are self explanatory and very easy to use.

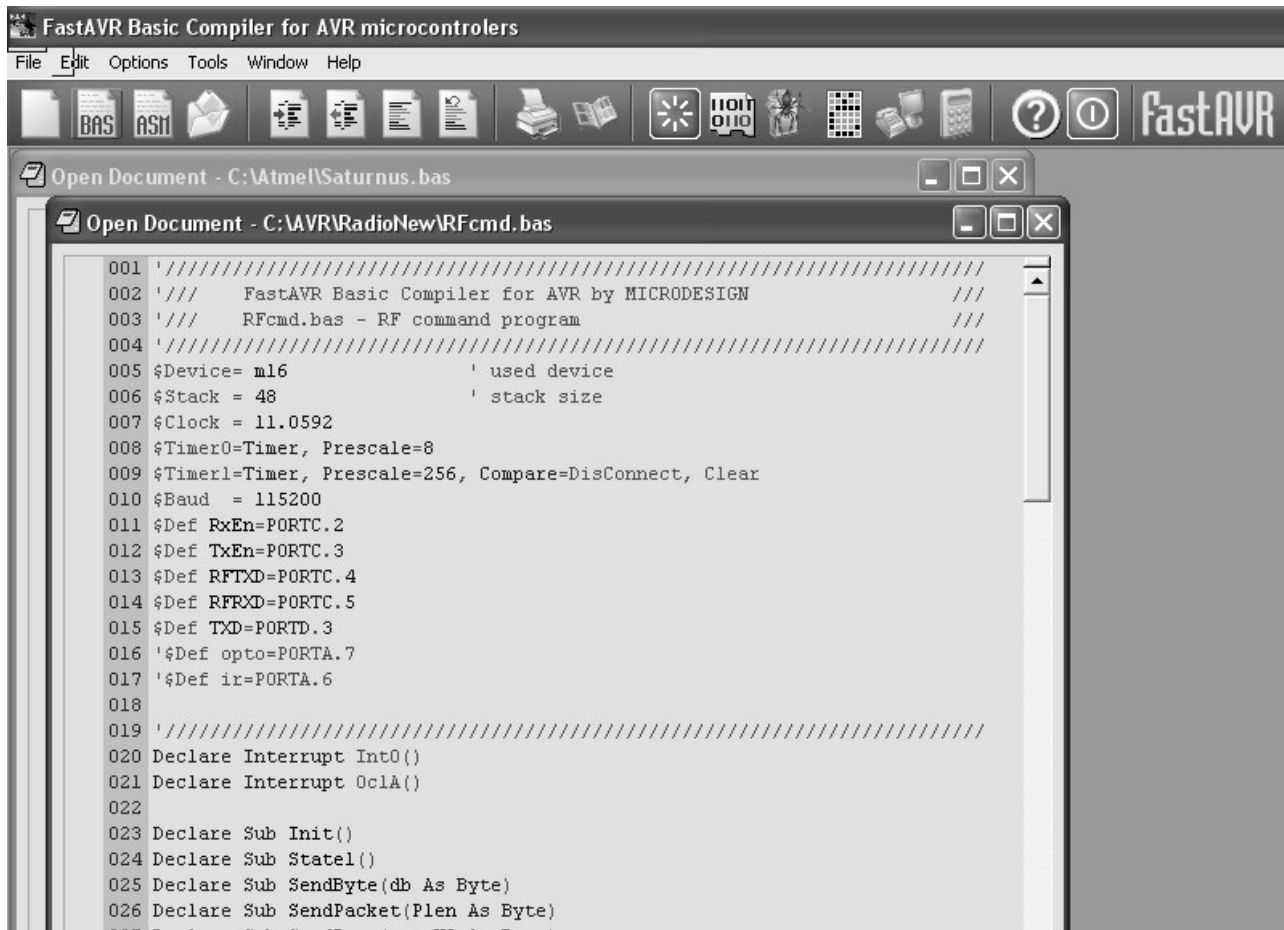

The main screen is used for editing files. More than one file can be open at once.  
 At the bottom is the Compiler status frame where compiled results can be viewed!

### 3.3. Keyboard Commands

Command	Keystroke
Compile	F5
Run LCD char gen	F4
Run Programmer	F6
Run Terminal Emulator	F9
Run AVR Calculator	F11
BookmarkNext	F2
BookmarkPrev	Shift + F2
BookmarkToggle	Control + F2
CharLeft	Left
CharLeftExtend	Shift + Left
CharRight	Right
CharRightExtend	Shift + Right
Copy	Control + C
Copy	Control + Insert
Cut	Shift + Delete
Cut	Control + X
CutSelection	Control + Alt + W
Delete	Delete
DeleteBack	Backspace
DocumentEnd	Control + End
DocumentEndExtend	Control + Shift + End
DocumentStart	Control + Home
DocumentStartExtend	Control + Shift + Home
Find	Alt + F3
Find	Control + F
FindNext	F3
FindNextWord	Control + F3
FindPrev	Shift + F3
FindPrevWord	Control + Shift + F3
FindReplace	Control + Alt + F3
GoToLine	Control + G
GoToMatchBrace	Control + ]
Home	Home
HomeExtend	Shift + Home
IndentSelection	Tab
LineCut	Control + Y
LineDown	Down
LineDownNextend	Shift + Down
LineEnd	End
LineEndExtend	Shift + End
LineOpenAbove	Control + Shift + N
LineUp	Up
LineUpExtend	Shift + Up
LowercaseSelection	Control + U
PageDown	Next
PageDownNextend	Shift + Next
PageUp	PRIOR
PageUpExtend	Shift + Prior
Paste	Control + V
Paste	Shift + Insert
Properties	Alt + Enter
RecordMacro	Control + Shift + R
Redo	F8
SelectLine	Control + Alt + F8
SelectSwapAnchor	Control + Shift + X
SentenceCut	Control + Alt + K
SentenceLeft	Control + Alt + Left

SentenceRight	Control + Alt + Right
SetRepeatCount	Control + R
TabifySelection	Control + Shift + T
ToggleOvertime	Insert
ToggleWhitespaceDisp	Control + Alt + T
Undo	Control + Z
Undo	Alt + Backspace
UnindentSelection	Shift + Tab
UntabifySelection	Control + Shift + Space
UppercaseSelection	Control + Shift + U
WindowScrollDown	Control + Up
WindowScrollLeft	Control + PageUp
WindowScrollRight	Control + PageDown
WindowScrollUp	Control + Down
WordDeleteToEnd	Control + Delete
WordDeleteToStart	Control + Backspace
WordLeft	Control + Left
WordLeftExtend	Control + Shift + Left
WordRight	Control + Right
WordRightExtend	Control + Shift + Right

### 3.4. Mouse Use

Mouse Action:	Result:
L-Button click over text	Changes the caret position
R-Button click	Displays the edit menu
L-Button down over selection, and drag	Moves text
Ctrl + L-Button down over selection, and drag	Copies text
L-Button click over left margin	Selects line
L-Button click over left margin, and drag	Selects multiple lines
Alt + L-Button down, and drag	Select columns of text
L-Button double click over text	Select word under cursor
Spin IntelliMouse mouse wheel	Scroll the window vertically
Single click IntelliMouse mouse wheel	Select the word under the cursor
Double click IntelliMouse mouse wheel	Select the line under the cursor
Click and drag splitter bar	Split the window into multiple views
Double click splitter bar	Split the window in half into multiple views

## 4. FastAVR Tools

### 4.1. AVR Studio

You can Debug or Simulate your program at assembler level using Atmel's free AVR Studio. For this purpose please load Obj file to AVR Studio!



When pressing the **DEBUG** button from the main toolbar for the first time you will be asked to locate the **AVR Studio** software!

Any further click of the Debug button will run AVR Studio!

[AVRStudio3](#) can be downloaded for simulating and/or debugging the assembler output file!

### 4.2. LCD Character Generator

The alphanumeric LCD can define up to eight special characters numbered from 0 to 7.

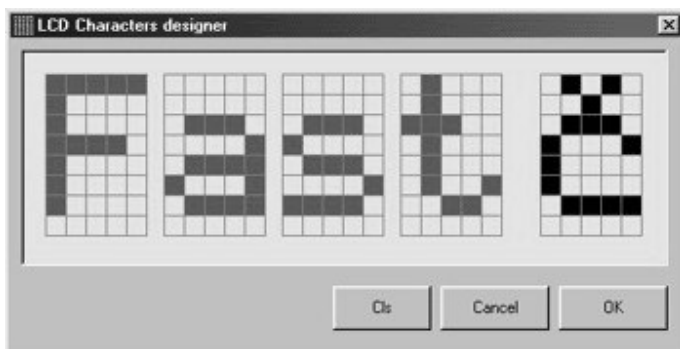

First design your character by clicking on LCD pixel blocks (left click- set pixel, right click- reset pixel). By pressing OK, the LCD designer will insert a special code at the current cursor position in the active document window.

```
DefLcdChar 0, &h0A, &h04, &h0E, &h11, &h10, &h10, &h0F, &h00
```

Zero after DefLcdChar is the Character number and must be edited in subsequent character definitions!

The new LCD character can be displayed on the LCD using the statement:

```
Lcd Chr(n)      'where n is the character number from 0 to 7
```

### 4.3. Terminal Emulator

When testing out the UART (hardware or software type), you may wish to monitor the output from your hardware. Terminal emulator will capture any ASCII output sent using the Print statement. While typing in Terminal Emulator, all characters are sent to your hardware and can be captured using Input. ComPort must first be configured for the correct Port (Com1, Com2), speed (9600,...) and other parameters! The Terminal Emulator port must be opened by clicking on the RED circle!

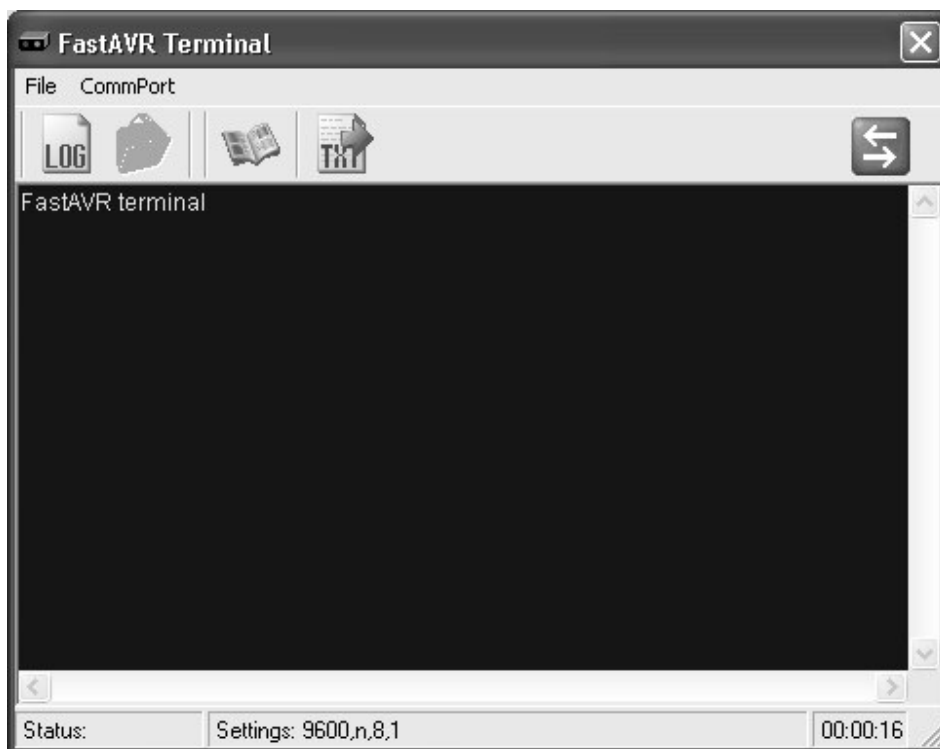

## 4.4. AVR Calculator

AVR calculator allows quick calculations for timer reload values based on the crystal used, needed time and prescale factor!

Calculated results are for Timer Overflow and for OutputCompare!

**FastAVR Calculator**

Used Crystal [MHz]

Needed Time [us]

Prescale

Timer0 Timer2

TCNTx  OCRx

Timer1 Timer3

TCNTxH  TCNTxL

OCRxAH  OCRxAL

Actual time [us]

## 4.5. Programmer

FastAVR runs Atmel's free ISP programming software installed on your PC (or any other programming software). Programming can be accomplished using a very simple programming dongle connected to your Parallel port. Here is the schematic to build one:

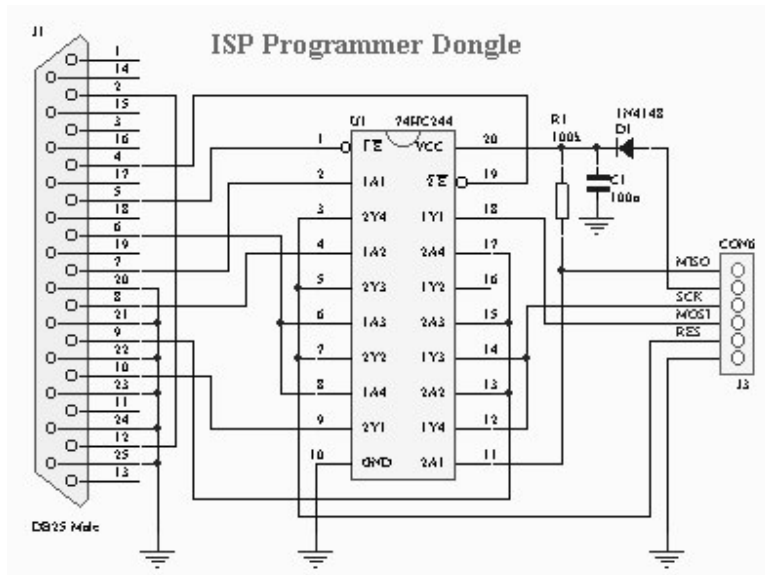

When pressing the **PROGRAM** button from the main tool bar the first time you will be asked to locate Your preferred programming software!

Any further click on the Program button will run the ISP programmer!

In addition, You can enter special Command line parameters if You are using such a Programmer!

You can download [ISP Programmer](#) from Atmels [www](#) !

## 5. AVR fundamentals

The best reading about AVR core is AVR data documents at [http://www.atmel.com/dyn/products/datasheets.asp?family\\_id=607](http://www.atmel.com/dyn/products/datasheets.asp?family_id=607).

## 6. FastAVR KeyWords

### 6.1. Meta - Statements

Meta-statements direct the compiler. Most are to configure compiler options. Some cue the compiler about the intended program actions, such as interrupt handling. Thus, some directives cause code from predefined libraries to be included.

Meta-statement keywords begin with "\$".

#### 6.1.1. Compiler directives

##### 6.1.1.1. \$Angles

*Description:*

Defines how Angles will be treated in Trigonometric functions.

*Syntax:*

```
$Angles = Degrees|Radians
```

*Remarks:*

Default is Radians.

*Example:*

```
$Angles=Degrees      'Angles are in Deegres
```

```
Dim f1 As Float
```

```
f1=Sin(30)           'f1=0.5000000
```

*Related topics:*

[Sin](#)

[Cos](#)

[Tan](#)

[Asin](#)

[Acos](#)

[Atan](#)

### 6.1.1.2. **\$Asm**

*Description:*

Starts an assembler program subroutine.

*Syntax:*

```
$Asm
```

*Remarks:*

This allows to use inline assembly code.

Always use \$Asm with \$EndAsm at the end of a block.

*Example:*

```
$Asm
    ldi    z1,0x65
    st     c, z1
$EndAsm
```

### 6.1.1.3. **\$Include**

*Description:*

Instructs the compiler to include a Basic source file from disk at that position.

*Syntax:*

```
$Include "Path\BasDoc.bas"
```

*Remarks:*

The compiler continues with the next statement in the original source file when it encounters the end of the included file. The result is the same as if the contents of the included file were physically present in the original source file.

*Example:*

```
$Include "C:\FastAVR\Init.bas"
$Include "C:\FastAVR\Font.bas"
```

### 6.1.1.4. **\$IncludeAsm**

*Description:*

Instructs the compiler to include a ASM source file from disk at the position.

*Syntax:*

```
$IncludeAsm "Path\Utils.asm"
```

*Remarks:*

The compiler just add included file in to generated ASM output, so only Assembler will compile it.

*Example:*

```
$Include "C:\FastAVR\Init.asm"
```

### 6.1.1.5. **\$Source**

*Description:*

Tells the compiler to add Basic statements as comments in the ASM file for easy debugging.

*Syntax:*

```
$Source=ON|OFF
```

Could be omitted, default is ON.

## 6.1.2. **Processor Configuration**

### 6.1.2.1. **\$Baud**

*Description:*

Defines the UART (or second UART) baud rate and optional settings. It is similar to bits per second, but includes other non-data bits (start, stop, mark) which add overhead.

*Syntax:*

```
$Baud = const [, Parity, DataBits, StopBits]
$Baud2 = const [, Parity, DataBits, StopBits] ' for second UART
```

IMPORTANT! If user will use UART in Default mode (No Parity, 8 data bits, 1 Stop bit) use short mode:

```
$Baud = 9600
```

Specifying Parity, ....., will add extra routines for handling this extra features!

*Remarks:*

const is the baud rate number with standard values:  
1200, 2400, 4800, 9600, 19200, 38400, 56600, 76800, 115200  
Higher Baud rates are possible on new Mega devices!

Parity N, O, E, M or S

DataBits 5, 6, 7, 8 or 9

StopBits 1 or 2 (in case of 9 DataBits, must be only 1 StopBit)



See the AVR datasheets for valid UART settings for the target microprocessor

*Example:*

```
$Baud = 9600
$Baud2 = 9600
```

*Related topics:*

[Baud](#)

[\\$Clock](#)

### 6.1.2.2. **\$Clock**

*Description:*

Defines for the compiler's use the frequency of the microprocessor's crystal input. This is used to calculate compiler-generated constants in the output of a compilation. These constants are used at run time to set the serial port(s) baud rates and for built-in functions which delay by looping.

*Syntax:*

```
$Clock=const
```

*Remarks:*

const is the frequency value of crystal used. (In MHz)

Check for max working frequency for specific microcontroller!



If the value given in the \$Clock meta-statement is not the actually implemented microprocessor frequency, the serial port baud rate will be in error. The baud rate must be within a few percent in order for successful and reliable communications over time and temperature variations. Also, the software delay loops and hardware timers will be in error.

*Example:*

```
$Clock = 3.6864 'Our crystal is 3.6864MHz
```

*Related topics:*

[\\$Baud](#)

[Baud](#)

### 6.1.2.3. **\$Device**

*Description:*

Declares which microprocessor product is the target for the generated code.

*Syntax:*

```
$Device=type [, Xram, FirstAdr, XramLength]
```

*Remarks:*

type refers to a particular microprocessor product.

The other parameters are optional and define external RAM if present, for those chips which support such.

*Example:*

```
$Device= 4433
```

```
$Device= 8515, Xram, 0, 32k
```

```
$Device= ATmega16
```

```
$Device= mega16
```

```
$Device= m16
```

```
$Device= tiny13
```

#### 6.1.2.4. **\$Stack**

*Description:*

Defines the stack size needed for the program based on the program's design, the needs of the run-time libraries created by the compiler, and the interrupt arrangements. The stack space is created by initialization code generated by the compiler.

The stack must include space for the following:

- The worst-case nesting of calls to SUBs and FUNCTIONS (return addresses)
- The worst-case nesting of parameters passed to FUNCTIONS
  - Passed parameters are stored on stack frames, based on their sizes
- The worst-case nesting of the above with their local variables
  - That is, the DIMs inside SUB or FUNCTION or INTERRUPT
- Plus space for interrupt procedures and saving of registers at interrupt



The necessary stack size is often underestimated by the programmer. This error causes all kinds and sorts of non-obvious run-time program failures under statistical probabilities of events. For microprocessors with small memories, estimating optimal stack size is a true challenge for the software engineer.

*Syntax:*

```
$Stack=num
```

*Remarks:*

num is the number of memory bytes reserved for stack space.

*Example:*

```
$Stack = 32  'stack will be 32 bytes deep
```

### 6.1.3. **I/O Configuration**

#### 6.1.3.1. **\$Def**

*Description:*

Gives a symbolic name to a particular AVR I/O port and a bit position within that port. This enables user-defined names based on the purpose of the I/O pins of the microprocessor in any given application.

*Syntax:*

```
$Def name=PORT.n
```

*Remarks:*

name is a valid symbol name for the compiler.

PORT is one of the predefined names of the microprocessor I/O port such as PORTA or PORTB

n one digit between 0 and 7 depicting the bit number in the port

*Example:*

```
$Def Led=PORT.1
```

```
.
.
Set Led
```

### 6.1.3.2. \$1Wire

*Description:*

Tells the compiler which PORT.pin the 1wire bus is connected to.

*Syntax:*

```
$1Wire=Port.pin [, PORT.pin1, PORT.pin2, ...]
```

*Remarks:*

PORT.pin is the name of the physical pin.

You can have more than one 1Wire bus. Each additional Port.pin has its own index, first is 0!  
Of course, You can connect also more 1Wire devices on each bus.

*Example:*

```
$1Wire=PORTD.2      '1Wire bus is connected to PortD.2
```

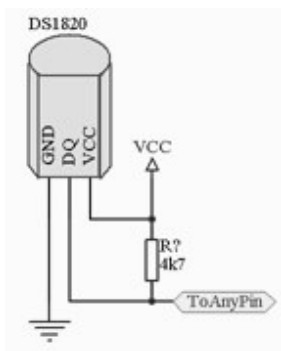

*Related topics:*

[1wreset](#)

[1wread](#)

[1wwrite](#)

### 6.1.3.3. \$DTMF

*Description:*

Reminds wher is OC1 output for DTMF signal generation.

*Syntax:*

```
$DTMF = PORT.pin, duration
```

*Remarks:*

Port must be Port where OC1 pin is located.

pin is a OC1 pin number.

duration in ms, max is 255!

*Example:*

```
DTMF
```

### 6.1.3.4. \$I2C

*Description:*

Defines the I2C bus pins connections for software single master configuration.

Hardware supported I2C on new Mega devices is not yet supported!

*Syntax:*

```
$I2C SDA=PORT.pin, SCL=PORT.pin
```

*Remarks:*

Tells the compiler which port pins SDA and SCL are connected to.

Dont forget pulup resistors on SDA and SCL (4k7 - 10k)!

*Example:*

```
$I2C SDA=PORTD.5, SCL=PORTD.6      'Defines I2C port pins
```

*Related topics:*

[I2CStart](#)

[I2CWrite](#)

[I2CRead](#)

[I2CStop](#)

### 6.1.3.5. \$Key

*Description:*

Defines the user defined keyboard matrix.

*Syntax:*

```
$Key Rows=PORT &hHexNum [, Cols=PORT &hHexNum] [, Hi] [, deb]
```

*Remarks:*

**AVRPort** is the name of the physical port.

**&hHexNum** is a two digit hex number representing keyboard wires

**Hi** this makes keys Active High (not for matrix organized keys)

**deb** is the debounce time in mseconds. Default is 20ms.

*Example1:*

```
'Defines four keys keyboard (keys in line)
$Key Rows=PORTD &h78
```

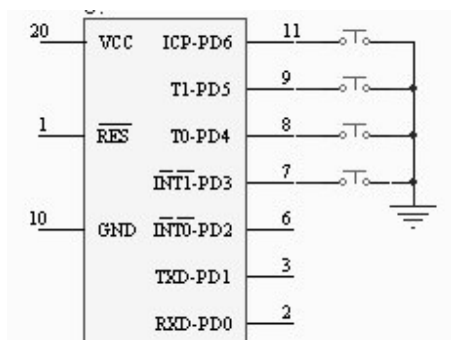

**Example2:**

```
'Defines matrix 5x4 Kbd connection (keys in matrix)
'debounce time is set to 50ms
$Key Rows=PORTB &hf8, Cols=PORTD &h74, 50
```

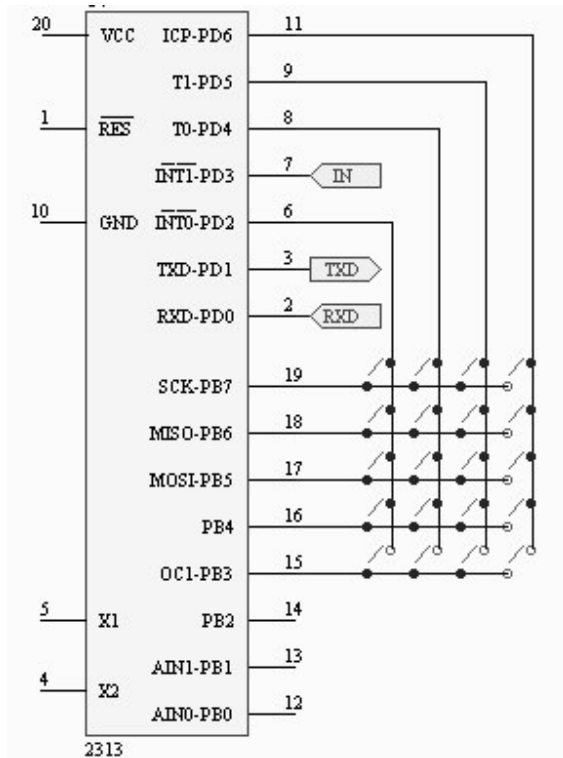
**Example3:**

```
'Defines three keys keyboard (keys in line), every keypress generates also External interrupt
INT0
$Key Rows=PORTB &he0
```

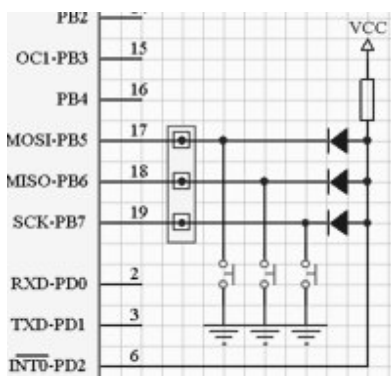
**Related topics:**

[Key\(\)](#)

**6.1.3.6. \$LeadChar***Description:*

Defines Leading Char for Print, Lcd, Tlcd, Glcd and Str(). All this outputs becomes RIGHT justified! Optionally defines also Format.

*Syntax:*

```
$LeadChar="single string constant" [, Format(Int,Frac)]
```

*Remarks:*

"single string constant" becomes Leading Char

**Int** Number of Integer numbers or Scientific

**Frac** Number of Fractal numbers

Note: LeadChar could be one for the whole project! Statement Format reserves two bytes of SRAM as system variables!

For Format statements read [Format](#).

*Example:*

```
n=5
$LeadChar="0", Format(3,1) 'lead char is "0", always will be three places left of decimal
Lcd n                    'output: 000.5

n=54321
Format(3,1)              'lead char is "0", always will be three places left of decimal
Lcd n                    'output: 432.1

n=5
Format(2,0)              'lead char is "0", always will be two places and no decimal point
Lcd n                    'output: 05
```

*Related topics:*

[Format](#)

**6.1.3.7. \$Lcd***Description:*

Tells the compiler which pins the alphanumeric LCD is connected to.

*Syntax:*

For 4bit port connection:

```
$Lcd=PORT.pin, rs=PORT.pin, en=PORT.pin, cols, rows
```

**RW pin MUST be wired to GND!**

For 8bit BUS connection:

```
$Lcd=Adr, rs=AdrRS, cols, rows
```

**ATTENTION! Configuration for STK-200 and STK-300 in bus mode:**

```
$Lcd=&h8000, rs=&hc000, cols, rows
```

A15 to generate EN, A14 for RS

*Remarks:*

Port is the name of the physical port. Any bidirectional or output port can be used!

pin is the name of the physical pin at which Lcd's D4 starts.

Adr is the Hex Address of the LCD connected in BUS mode.

AdrRS is the Hex Address of the LCD RS signal connected in BUS mode.

cols are the number of columns of the LCD.

rows are the number of rows of the LCD.

**ATTENTION! The shortest code will generate `$Lcd=PORTx . 0` or `PORTx . 4`, upper or lower nibble!  
Lcd pin RW MUST be soldered to GND!**

*Example:*

```
$Lcd=PORTD.4, rs=PORTB.0, en=PORTB.1, 16, 2 'LCD Defined as 16x2
```

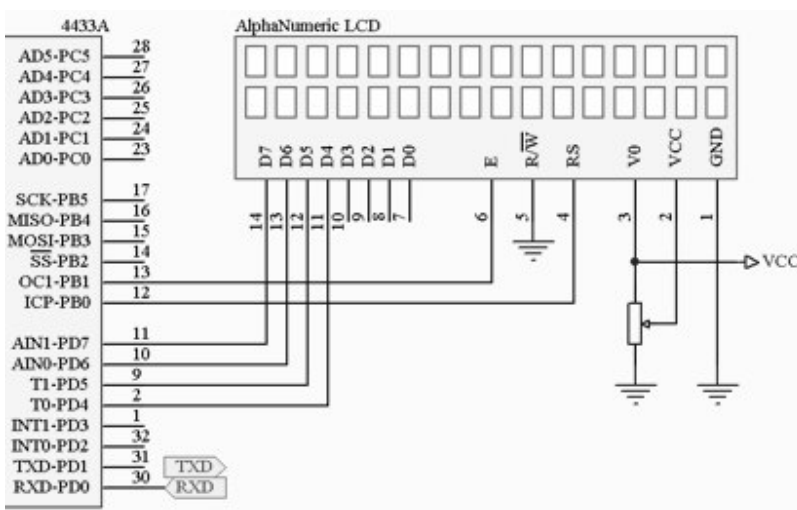
*Related topics:*

[LCD](#)

[Locate](#)

[Display](#)

[Cursor](#)

[InitLcd](#)

### 6.1.3.8. \$PcKey

*Description:*

Configures AT Keyboard connection

*Syntax:*

```
$PcKey data=PORT.pin1, clock=PORT.pin2 [, NoInit]
```

*Remarks:*

data line for PcKey is connected to AVRport.pin1. Any bidirectional PORT.pin can be used!

NoInit option for skip Initialize PcKeyboard (usefull if BarCode reader is attached instead of PcKeyboard).

clock line for PcKey is connected to AVRport.pin2

*Example:*

[PcKey\(\)](#)

*Related topics:*

[PcKeySend\(\)](#)

### 6.1.3.9.     **\$RC5**

*Description:*

Configures Phillips RC5 IR receiving.

*Syntax:*

```
$RC5 = PORT.pin
```

*Remarks:*

**Port** is the name of the physical port.

**pin** is a pin number where IR receiver is connected.

*Example:*

[RC5](#)

*Related topics:*

[RC5](#)

### 6.1.3.10.    **\$ShiftOut**

*Description:*

Tells the compiler the name of the AVR pin for ShiftOut or ShiftIn

*Syntax:*

```
$Shiftout Data=PORT.pin, Clock=PORT.pin, Msb [Lsb]
```

*Remarks:*

**Port** is the name of the physical port.

**Msb** for Most significant bit first, **Lsb** for Less significant bit first

**Routines works for both Clock polarities!**

Very usefull for expanding IO lines using shift registers!

*Example:*

```
$Shiftout Data=PORTB.0, Clock=PORTB.1, 1
```

*Related topics:*

[ShiftOut](#)

[ShiftIn](#)

**6.1.3.11. \$Sound***Description:*

Configures AVR pin for Sound output.

*Syntax:*

```
$Sound = PORT.pin
```

*Remarks:*

AVRPort is the name of the physical port.

pin is a pin number where (buffered speaker or buzzer) is connected.

*Example:*

```
$Sound = PORTD.2    ' this pin for sound output
```

*Related topics:*

[Sound](#)

**6.1.3.12. \$Spi***Description:*

Defines the SPI bus parameters.

*Syntax:*

```
$Spi num, Lsb|Msb, Master|Slave, Hi|Low, Hi|Low
```

*Remarks:*

num is the Clock division number for setting speed: 4, 16, 64, 128

Lsb or Msb tells which bit will be shifted out first.

First Hi or Low for Clock polarity (see Atmel's data)

Second Hi or Low for Clock Phase (see Atmel's data)

Note: During SPI initialization as Master Clk and MOSI are set to be output. SS must be held high!

*Example:*

```
$Spi 128, Lsb, Master, Hi, Low
```

*Related topics:*

[SPIN](#)

[SPIOut](#)

**6.1.3.13. \$Timer***Description:*

Defines the mode for Timers.

```
$Timer0=Timer [, Prescale=const, Async, Compare= Set|Reset|Toggle|DisConnected, Clear]
```

```
$Timer0=Counter, Rising|Falling [, Compare= Set|Reset|Toggle|DisConnected, Clear]
```

```
$Timer0=PWM, 8|9|10, Normal|Inverted|DisConnected [,Prescale=8]
```

```
$Timer1=Timer [, Prescale=const,
```

```
Compare=Set|Reset|Toggle|Disconnected, CompareA=Set|Reset|Toggle|Disconnected,
CompareB=Set|Reset|Toggle|Disconnected, Clear, Capture=Rising|Falling, NoiseCancel]
```

```
$Timer1=Counter, Rising|Falling [, Compare=Set|Reset|Toggle|Disconnected,
CompareA=Set|Reset|Toggle|Disconnected, CompareB=Set|Reset|Toggle|Disconnected,
Clear, Capture =Rising|Falling, NoiseCancel]
$Timer1=PWM, 8|9|10, PwmA|PwmB=Normal|Inverted|Disconnected [, Prescale=8]
```

```
$Timer2=Timer [, Prescale=8, Async, Compare=Set|Reset|Toggle|Disconnected, Clear]
$Timer2=Counter, Rising|Falling [, Compare= Set|Reset|Toggle|Disconnected, Clear]
$Timer2=PWM, 8|9|10, Normal|Inverted|Disconnected [, Prescale=8]
```

```
$Timer3=Timer [, Prescale=const,
Compare=Set|Reset|Toggle|Disconnected, CompareA=Set|Reset|Toggle|Disconnected,
CompareB=Set|Reset|Toggle|Disconnected, Clear, Capture=Rising|Falling, NoiseCancel]
```

```
$Timer3=Counter, Rising|Falling [, Compare=Set|Reset|Toggle|Disconnected,
CompareA=Set|Reset|Toggle|Disconnected, CompareB=Set|Reset|Toggle|Disconnected,
Clear, Capture =Rising|Falling, NoiseCancel]
$Timer3=PWM, 8|9|10, PwmA|PwmB=Normal|Inverted|Disconnected [, Prescale=8]
```

*Remarks:*

const can be 1, 8, 64, 256, 1024, for Timer0 and Timer2 also 32 and 128 (not for all devices!)

Normal Timers are clocked with Non prescaled Clock in PWM and Compare modes. If the user wishes to use lower frequencies just combine statements, such as:

```
$Timer0=Timer, Prescale=256      ' Clock will be divided by 256
$Timer0=PWM, 8, Normal|Inverted  ' PWM will now use prescaled clock
```

In PWM mode, Use special variables: Pwm0, Pwm1A, Pwm1B, Pwm2.

In OutCompare mode, Use special variables: Compare0, Compare1A, Compare1B, Compare2.

See the manual for Timer usage!

*Example:*

```
$Timer0=Timer, Prescale=1
$Timer1=PWM, 8, PwmA=Inverted
```

### 6.1.3.14. \$WatchDog

*Description:*

Defines the WatchDog time constant.

*Syntax:*

```
$WatchDog=const
```

*Remarks:*

const is the aprox. time in ms (at Vcc=5V) after which will WatchDog mechanism reset AVR device (16, 32, 64, 128, 256, 512, 1024, 2048).

*Example:*

```
$WatchDog = 2048  'About two seconds
```

*Related topics:*

[Start](#)

[Stop](#)

[Reset](#)

## 6.2. HD61202, KS0108B and SEP1520 Graphic LCD support

### 6.2.1. General

Graphic LCD (Hitachi HD61202 and Samsung KS1080B) usage.

Most commonly used graphic LCD has 128 x 64 pixels and it is produced by many manufacturers like Seiko (G1216), Hantronix (HDM64GS12), Samsung, WM-G1206,....

Pages are organized in rows (Lines), each being 8 pixels high. The number of Lines depends on the resolution of the particular display. For example, a 128 x 64 lcd would have 8 Lines, while a 128 x 32 lcd would only have 4 Lines. Some statements are Line oriented, not pixel. For instance, text can be written only on Lines, not in between.

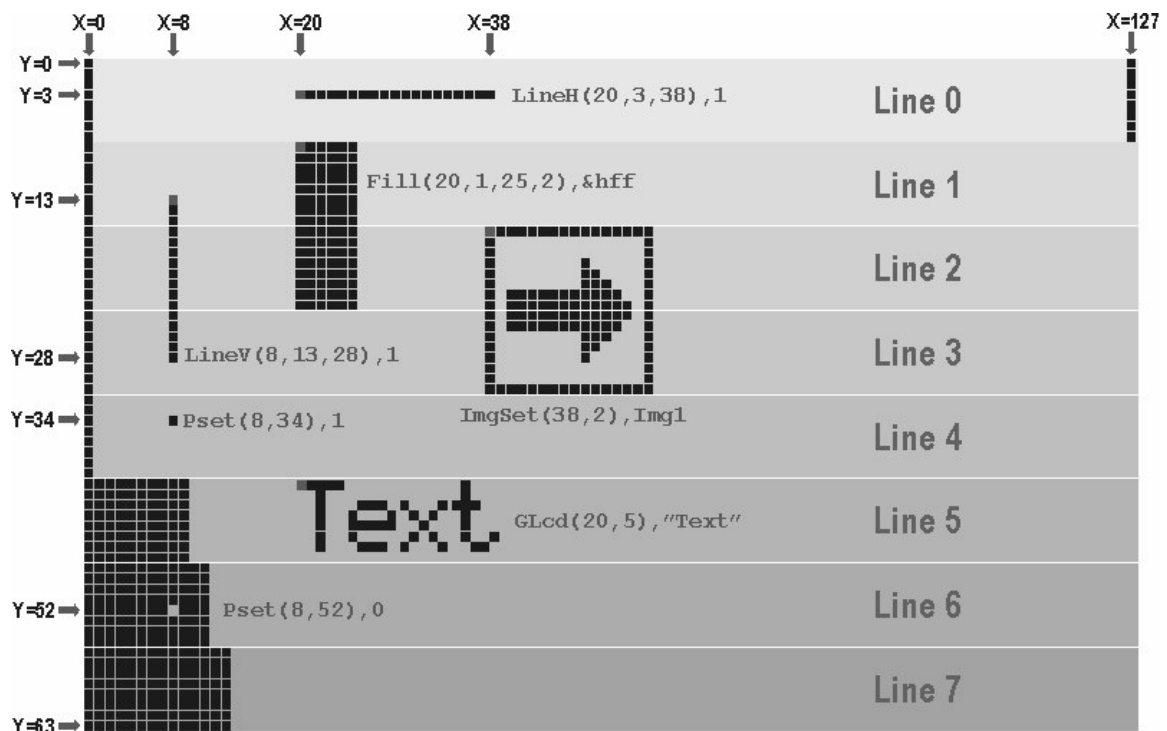

Most displays using the HD61202 and KS0108B chipset are separated into two banks. Each bank is addressed by the use of two chip select lines (CS1 and CS2). Therefore, a 128 x 64 display would be treated like two (64 x 64) displays.

For more information on Lcd Graphic displays please refer to the datasheets.

Support for SEP1520 is done for popular 122 x 32 pix module format. Only \$GCtrl is deeferente!

## 6.2.2. \$GLCD, \$GCtrl

### Description:

Tells the compiler details about Graphic LCD connections.

### Syntax:

```
$GLCD HD61202, Data=AVRPort, Ctrl=AVRPort, NumOfXpix, NumOfYpix, i
$GCtrl EN=4, WR=3, DI=2, CS1=0, CS2=1
```

### For SEP1520:

```
$GCtrl A0=4, RW=3, E1=0, E2=1
```

### Remarks:

**HD61202** or **KS0108B** is the graphic controller chip used

**Data** AVRPort where data bus is connected

**Ctrl** AVRPort where control lines are connected

**AVRPort** any valid AVRPort. Any bidirectional port can be used!

**NumOfXpix** how many Pixels LCD has on X

**NumOfYpix** how many Pixels LCD has on Y

**i** type of init routine, could be **1, 2 or 3**

**EN, WR, DI, CS1, CS2** valid Control line names for HD61202 and KS0108B

**A0, RW, E1, E2** valid Control line names for SEP1520D61202

**Note:** Because of differences in Graphic Lcds, no provision is made for a hardware reset.

You may, however, assign any valid AvrPort pin that is available or use an appropriate RC setup for the LCD module reset. Please refer to the datasheet or manual for the specific graphic LCD module being used.

Control lines can be declared in any order!

### Example:

```
$GLCD HD61202, Data=PORTB, Ctrl=PORTD, 128, 64, 1
$Gctrl EN=4, WR=3, DI=2, CS1=0, CS2=1
```

'EN is connected to PORTD.4, WR to PORTD.3...

## 6.2.3. Fill

### Description:

Fills specified area with a byte pattern.

### Syntax:

```
Fill(varX, varL, varX1, varL1), Pat
```

### Remarks:

**varX** LeftMost X coordinate of area, normally between 0 and 126

**varL** TopMost Line of area, normally between 0 and 6

**varX1** RightMost X coordinate of area, normally between 1 and 127

**varL1** BottomMost Line of area, normally between 1 and 7

**Pat** Byte the area will be filled with

**varX1** must be greater than **varX** and **varL1** must be greater than **varL**.

Y coordinates are in Lines not in Pixels! Also suitable for clearing a specific area.

*Example:*

```
Fill(15, 1, 60, 4), &haa ' Specified area will be filled with &haa
```

*Related Topics:*

Inverse

GC1s

## 6.2.4. FontSet

*Description:*

Selects soft Font.

*Syntax:*

```
FontSet NameOfFontTable
```

*Remarks:*

**NameOfFontTable** Table in Flash that contains individual letter definitions.

NameOfFontTable must be declared first and added into source (\$Included)!

Fonts can be edited with the FastLCD utility and saved in **bas** format ready to include in source!

Selected Font is active until another Font is selected with FontSet.

*Example:*

```
Dim FOHD As Flash Byte
```

```
Dim F1HD As Flash Byte
```

```
Dim n As Byte
```

```
Dim s As String*20
```

```
n=15
```

```
s="Graphic LCD"
```

```
FontSet F1HD
```

```
' Selects F1
```

```
GLcd(15, 0), n
```

```
' Writes n with F1
```

```
GLcd(15, 7), s
```

```
' Writes w with F1
```

```
FontSet FOHD
```

```
' Selects F0
```

```
GLcd(15, 1), "HD61202"
```

```
' Writes txt with F0
```

```
$Included "C:\FastAVR\F0HD.bas" ' Here is 6x8 font definition
```

```
$Included "C:\FastAVR\F1HD.bas" ' Here is 8x8 font definition
```

*Related Topics:*

GLcd

### 6.2.5. Gcls

*Description:*

Clears the Graphic LCD

*Syntax:*

Gcls

*Example:*

```
Gcls      ' Graphic LCD is now cleared
```

### 6.2.6. Glcd

*Description:*

Writes text on graphic LCD using previously specified soft Font.

*Syntax:*

GLcd(**varX**, **varP**), **var**

*Remarks:*

**varX** Starting X coordinate, normally between 0 and 127

**varP** Line to write in, between 0 and 7

**var** num, string, string constant or hex to write

Y coordinates are in Lines not in Pixels!

Font MUST be set (FontSet) prior to using GLcd!

If You wish to show just a few words, maybe ImgSet is better (shorter) solution (word is made as an Image)!

If \$LeadChar is defined then result will be right justified with Leading Chars as defined. Also, if Format() is defined then optional decimal point will be inserted!

*Example:*

```
GLcd(15, 0), n      ' Writes num variable on upper Line
GLcd(15, 1), s      ' Writes string var on second Line
GLcd(15, 2), "This is HD61202"  ' Writes string on third Line
GLcd(15, 3), Chr(61)  ' Writes letter A on 4. Line
GLcd(15, 4), Hex(61)  ' Writes Hex string on 5. Line
```

*Related Topics:*

FontSet

### 6.2.7. GlcdInit

*Description:*

Initializes the Graphic LCD display

*Syntax:*

GLcdInit

*Example:*  
`GLcdInit`

*Remarks:*

`$GLCD` and `$GCtrl` must be setup prior to using `GLcdInit`.

At initial power on or anytime the graphic LCD is powered down, `GLcdInit` should be called to initialize the LCD before using any graphic statements.

Some LCDs has theirs own internal RESET, for others user MUST generate RESET (active LOW) before Calling `GLcdInit!`

### 6.2.8. GRead

*Description:*

Reads a byte from the graphic LCD at selected X and Line.

*Syntax:*

`Var = GRead(varX, varL)`

*Remarks:*

**varX** X coordinate, normally between 0 and 127

**varL** Line, between 0 and 7

**var** is assigned the value read

This is the graphic controllers native Read function.

Y coordinates are in Lines not in Pixels!

*Example:*

`n = GRead(17, 2)` ' Data from x=17 on Line 2 will be Read into n.

*Related Topics:*

`Gwrite`

### 6.2.9. GWrite

*Description:*

Writes a byte at selected X and Line.

*Syntax:*

`GWrite(varX, varL), var`

*Remarks:*

**varX** X coordinate, normally between 0 and 127

**varL** Line, between 0 and 7

**var** to be written to desired position.

This is the graphic controllers native Write function.

Y coordinates are in Lines not in Pixels!

*Example:*

```
GWrite(17, 2), 15 ' Four pixels will be written to x=17 on the Line 2.
```

*Related Topics:*

GRead

## 6.2.10. ImgSet

*Description:*

Displays an Image or a part of ImageArray on the graphic LCD at selected X and Line.

*Syntax:*

```
ImgSet (varX, varP), NameOfImgTable
```

Or, if You wat to display just a part of an ImageArray:

(Image must be saved as ImageArray, when edited using FastLCD utility!)

```
ImgSet (varX, varP, var), NameOfImgTable
```

*Remarks:*

**varX** X coordinate, normally between 0 and 127

**varL** Line, between 0 and 7

**var** which part of Image, (index in ImageArray)

**NameOfImgTable** Table in Flash that contains the bit image.

Y coordinates are in Lines not in Pixels!

**NameOfImgTable** must be declared first and added into source (\$Included)!

Images can be edited with FastLCD image editor which can save Images in **bas** format.

The saved image is then ready to be included in the source program!

*Example:*

```
Dim Img0 As Flash Byte
```

```
Dim Img1 As Flash Byte
```

```
ImgSet(15, 2), Img1 ' Image Img1 will be copied to location
```

```
$Included "C:\FastAVR\Img0.bas" ' Img0 bit image definition
```

```
$Included "C:\FastAVR\Img1.bas" ' Img1 bit image definition
```

*Second syntax:*

Using ImageArray, a large letters, Icons or Sprites can be displayed, all saved in a single Image!

Any part of this Image is accessible by its index, yea - this means animations!



*Example:*

```
Dim Sclk1616HD As Flash Byte
```

```
ImgSet(15, 2, 1), Sclk1616HD ' SandClock with index 1
```

```
$Included "C:\FastAVR\Sclk1616HD.bas" ' SandClock definition
```

*Related Topics:*

GLcd

### 6.2.11. Inverse

*Description:*

Inverses specified area on the screen.

*Syntax:*

```
Inverse(varX, varL, varX1, varL1)
```

*Remarks:*

**varX** LeftMost X coordinate of area, normally between 0 and 126

**varL** TopMost Line of area, normally between 0 and 7

**varX1** RightMost X coordinate of area, normally between 1 and 127

**varL1** BottomMost Line of area, normally between 0 and 7

**varX1** must be greater than **varX** and **varL1** must be greater than **varL**.

Y coordinates are in Lines not in Pixels!

*Example:*

```
Inverse(15, 1, 60, 4) ' Specified area will be Inversed
```

*Related Topics:*

Fill

### 6.2.12. LineH

*Description:*

Draws or Clears a Horizontal Line.

*Syntax:*

```
LineH(varX, varY, varX1), 0|1
```

*Remarks:*

**varX** X coordinate of LeftMost pixel in Line, normally between 0 and 126

**varY** Y coordinate of Line, normally between 0 and 63

**varX1** X coordinate of RightMost pixel in Line, normally between 1 and 127

**0|1** 0 will Clear Line, 1 will Draw Line

**varX1** must be greater than **varX**.

*Example:*

```
LineH(15, 20, 120), 1 ' Line will be Drawn from X=15 to 120, at y=20
```

*Related Topics:*

LineV

### 6.2.13. LineV

*Description:*

Draws or Clears a Vertical Line.

*Syntax:*

```
LineV(varX, varY, varY1), 0|1
```

*Remarks:*

**varX** X coordinate of Line, normally between 0 and 127

**varY** Y coordinate of TopMost pixel in Line, normally between 0 and 62

**varY1** Y coordinate of BottomMost pixel in Line, normally between 1 and 63

**0|1** 0 will Clear Line, 1 will Draw Line

**varY1** must be greater than **varY**.

*Example:*

```
LineV(15, 20, 60), 1 ' Vertical Line will be Drawn from y=20 to 60, at x=15
```

*Related Topics:*

LineH

### 6.2.14. Point

*Description:*

Tests if specified Pixel location is Set or Reset.

*Syntax:*

```
Var = Point(varX, varY)
```

*Remarks:*

**varX** X coordinate, normally between 0 and 127

**varY** Y coordinate, between 0 and 63

**var** is assigned the result, 0 if pixel is Reset, 1 if Pixel is Set

*Example:*

```
n = Point(15, 2) ' If n>0 that Pixel is Set
```

*Related Topics:*

PSet

### 6.2.15. Pset

*Description:*

Sets or Resets an individual Pixel at the desired position.

*Syntax:*

`Pset (varX, varY), 0|1`

*Remarks:*

**varX** X coordinate, normally between 0 and 127

**varY** Y coordinate, normally between 0 and 63

**0|1** 0 will Reset pixel, 1 will Set pixel, (color)

*Example:*

`Pset (15, 20), 1` ' Pixel at coordinates 15, 20 will be Set

*Related Topics:*

Point

LineH

LineV

## 6.3. PCD8544 - NOKIA 3310

### 6.3.1. General

Nokia 3310 has very nice, not expensive Graphic display 84 x 48 pixels.

Here <http://www.myplace.nu/mp3/nokialcd.htm> You can find more data.

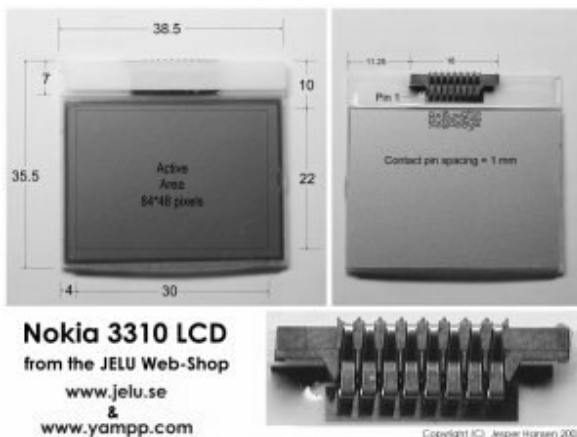

Pages are organized in rows (Lines), each being 8 pixels high. There are 6 Lines. Some statements are Line oriented, not pixel. For instance, text can be written only on Lines, not in between.

Display has serial interface using only four signals plus RESET which could be driven by RC.

Unfortunately, display has not possibility to Read from. This dont allow as to have standard graphic functions like Pset, Line and similar. To avoid this limitation a Buffer of 504 bytes could be reserved and all Drawings must be performed in this Buffer. This is for upgrading - if there will be enough interest!

Another possibility is to use SPI as serial interface - this is much faster transfer.

Display Coonection

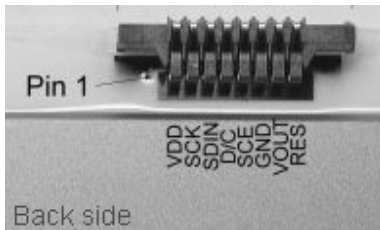

Dont forget a 470nF capacitor beetween Vout and GND!

Look at `Nokia3310.bas`

### 6.3.2. \$GLCD

*Description:*

Tells the compiler details about Graphic LCD connections.

*Syntax:*

```
$GLCD PCD8544, SDIN=PORTx.n, SCLK=PORTx.n, DC=PORTy.n, SCE=PORTy.n
```

*Remarks:*

**PCD8544** or **NOKIA3310** is the graphic controller chip used  
**SDIN**, **SCLK**, **DC**, **SCE** Nokia display signals names.

**SDIN** and **SCLK** MUST be on the same PORT!

**DC** and **SCE** MUST be on the same PORT!

Control signals can be declared in any order!

You may also assign any valid AvrPort pin that is available for RESET Graphic module or use an appropriate RC setup for the LCD module reset like 10k PullUp resistor with 100nF capacitor to GND.

*Example:*

```
$GLCD NOKIA3310, SDIN=PORTA.0, SCLK=PORTA.1, DC=PORTA.2, SCE=PORTA.3
```

### 6.3.3. Contrast

*Description:*

Sets Nokia LCD module contrast.

*Syntax:*

**Contrast**=numeric expression

*Remarks:*

numeric expression Value from 0 to 127 to set contrast (default is 72).

*Example:*

```
For n=50 To 120
  Contrast=n      ' finding best contrast
  Wait 1
Next
```

### 6.3.4. FontSet

*Description:*

Selects soft Font.

*Syntax:*

**FontSet NameOfFontTable**

*Remarks:*

**NameOfFontTable** Table in Flash that contains individual letter definitions.

NameOfFontTable must be declared first and added into source (\$Included)!

Fonts can be edited with the FastLCD utility and saved in **bas** format ready to include in source!

Selected Font is active until another Font is selected with FontSet.

*Example:*

```
Dim F0HD As Flash Byte
Dim F1HD As Flash Byte
Dim n As Byte
Dim s As String*20

n=15
s="Graphic LCD"
FontSet F1HD      ' Selects F1
GLcd(15, 0), n    ' Writes n with F1
GLcd(15, 7), s    ' Writes w with F1

FontSet F0HD      ' Selects F0
GLcd(15, 1), "HD61202" ' Writes txt with F0

$Included "C:\FastAVR\F0HD.bas" ' Here is 6x8 font definition
$Included "C:\FastAVR\F1HD.bas" ' Here is 8x8 font definition
```

*Related Topics:*

GLcd

### 6.3.5. GLcd

*Description:*

Writes text on graphic LCD using previously specified soft Font.

*Syntax:*

`GLcd(varX, varP), var`

*Remarks:*

**varX** Starting X coordinate, normally between 0 and 83

**varP** Line to write in, between 0 and 5

**var** num, string, string constant or hex to write

Y coordinates are in Lines not in Pixels!

Font MUST be set (`FontSet`) prior to using `GLcd`!

If You wish to show just a few words, maybe `ImgSet` is better (shorter) solution (word is made as an Image)!

If `$LeadChar` is defined then result will be right justified with Leading Chars as defined. Also, if `Format()` is defined then optional decimal point will be inserted!

*Example:*

```
GLcd(15, 0), n           ' Writes num variable on upper Line
GLcd(15, 1), s           ' Writes string var on second Line
GLcd(15, 2), "This is HD61202" ' Writes string on third Line
GLcd(15, 3), Chr(61)     ' Writes letter A on 4. Line
GLcd(15, 4), Hex(61)    ' Writes Hex string on 5. Line
```

*Related Topics:*

`FontSet`

### 6.3.6. Gwrite

*Description:*

Writes a byte at selected X and Line.

*Syntax:*

`GWrite(varX, varL), var`

*Remarks:*

**varX** X coordinate, normally between 0 and 83

**varL** Line, between 0 and 5

**var** to be written to desired position.

This is the graphic controllers native Write function.

Y coordinates are in Lines not in Pixels!

*Example:*

```
GWrite(17, 2), 15      ' Four pixels will be written to x=17 on the Line 2.
```

### 6.3.7. ImgSet

*Description:*

Displays an Image or a part of ImageArray on the graphic LCD at selected X and Line.

*Syntax:*

```
ImgSet (varX, varP), NameOfImgTable
```

Or, if You wat to display just a part of an ImageArray:

(Image must be saved as ImageArray, when edited using FastLCD utility!)

```
ImgSet (varX, varP, var), NameOfImgTable
```

*Remarks:*

**varX** X coordinate, normally between 0 and 83

**varL** Line, between 0 and 5

**var** which part of Image, (index in ImageArray)

**NameOfImgTable** Table in Flash that contains the bit image.

Y coordinates are in Lines not in Pixels!

**NameOfImgTable** must be declared first and added into source (\$Included)!

Images can be edited with FastLCD image editor which can save Images in **bas** format.

The saved image is then ready to be included in the source program!

*Example:*

```
Dim Img0 As Flash Byte
```

```
Dim Img1 As Flash Byte
```

```
ImgSet(15, 2), Img1 ' Image Img1 will be copied to location
```

```
$Included "C:\FastAVR\Img0.bas" ' Img0 bit image definition
```

```
$Included "C:\FastAVR\Img1.bas" ' Img1 bit image definition
```

*Second syntax:*

Using ImageArray, a large letters, Icons or Sprites can be displayed, all saved in a single Image!

Any part of this Image is accessible by its index, yea - this means animations!



*Example:*

```
Dim Sclk1616HD As Flash Byte
```

```
ImgSet(15, 2, 1), Sclk1616HD ' SandClock with index 1, second sub-Image will be displayed
```

```
$Included "C:\FastAVR\Sclk1616HD.bas" ' SandClock definition
```

*Related Topics:*

GLcd

### 6.3.8. Inverse

*Description:*

Sets NORMAL or INVERSE screen.

*Syntax:*

`Inverse (var)`

*Remarks:*

`var` 0 - normal, 1 - inverse

Only whole display can be Inversed!

*Example:*

```
Inverse(1)    ' Screen is Inversed
```

### 6.3.9. Gcls

*Description:*

Clears the Graphic LCD

*Syntax:*

`Gcls`

*Example:*

```
Gcls    ' Graphic LCD is now cleared
```

## 6.4. T6963C Graphic LCD support

### 6.4.1. \$GLCD, \$Gctl

*Description:*

Tells the compiler details about Graphic LCD connections.

*Syntax:*

```
$GLCD T6963C, Data=AVRPort, Ctrl=AVRPort, NumOfXpix, NumOfYpix, i
$Gctl  WR=4, RD=3, CE=2, CD=1, FS=1
```

*Remarks:*

**T6963C** is the graphic controller chip used

**Data** AVRPort where data bus is connected.

**Ctrl** AVRPort where control lines are connected.

**AVRPort** any valid AVRPort. Any bidirectional port can be used!

**NumOfXpix** how many Pixels LCD has on X

**NumOfYpix** how many Pixels LCD has on Y

**i** 1 for single, 2 for double scan graphic LCD display module (low pix modules has single scan, larges double scan. Look datasheets for details)

**WR, RD, CE, CD** valid Control line names for T6963C

**FS** 1 for 6x8 and 0 for 8x8 fonts - tells how Bytes will be using (6 or 8 bits)

**Note:** Because of differences in Graphic Lcds, no provision is made for a hardware reset.

You may, however, assign any valid AvrPort pin that is available or use an appropriate RC setup for the LCD module reset. Please refer to the datasheet or manual for the specific graphic LCD module being used.

FontSelect (FS) MUST be fixed to 1 for 6x8 internal Font and 6 pix wide column or fixed to 1 for 8x8 internal Font and 8 pix wide column.

Control lines can be declared in any order!

*Example:*

```
$GLCD T6963C, Data=PORTB, Ctrl=PORTD, 128, 64, 1
$Gctrl WR=4, RD=3, CE=2, CD=1, FS=1
```

'WR is connected to PORTD.4, RD to PORTD.3...

## 6.4.2. Box

*Description:*

Draws or Clears a box.

*Syntax:*

```
Box(varX0, varY0, varX1, varY1), 0|1
```

*Remarks:*

**varX0** X coordinate of Upper Left corner

**varY0** Y coordinate of Upper Left corner

**varX1** X coordinate of Lower Right corner

**varY1** Y coordinate of Lower Right

**0|1** 0 will Clear Line, 1 will Draw Line

*Example:*

```
Circle(0, 0, 239, 127), 1 ' Rectangle around 240x128 pix LCD
```

*Related Topics:*

[Pset](#)

[Line](#)

[Circle](#)

[LineH](#)

[LineV](#)

### 6.4.3. Circle

*Description:*

Draws or Clears a Circle.

*Syntax:*

```
Circle(varX, varY, radius), 0|1
```

*Remarks:*

**varX** X coordinate of center

**varY** Y coordinate of center

**radius** of the circle

0|1 0 will Clear Line, 1 will Draw Line

*Example:*

```
Circle(120, 64, 60), 1 ' Circle on center 240x128 pix LCD, r=60
```

*Related Topics:*

[Line](#)

[Box](#)

[LineH](#)

[LineV](#)

[Pset](#)

### 6.4.4. Fill

*Description:*

Fills specified area on the screen.

*Syntax:*

```
Fill(varX, varY, varX1, varL1), Pat
```

*Remarks:*

**varX** LeftMost X coordinate of area, between 0 and NofColumns

**varL** TopMost coordinate, between 0 and Ymax

**varX1** number of columns to Inverse

**varL1** number of lines (pixels) to Inverse

**Pat** Byte the area will be filled with

X coordinates are in Columns not in Pixels! Also suitable for clearing a specific area.

*Example:*

```
Fill(15, 1, 6, 40), &haa ' Specified area will be filled with &haa
```

*Related Topics:*

[GCIs](#)

[Inverse](#)

### 6.4.5. FontSet

*Description:*

Selects soft Font.

*Syntax:*

**FontSet** **NameOfFontTable**

*Remarks:*

**NameOfFontTable** Table in Flash that contains individual letter definitions.

NameOfFontTable must be declared first and added into source (\$Included)!

Fonts can be edited with the FastLCD utility and saved in **bas** format ready to include in source!

Selected Font is active until another Font is selected with **FontSet**.

*Example:*

```
Dim F0T As Flash Byte
Dim F1T As Flash Byte
Dim n As Byte
Dim s As String*20
```

```
n=15
```

```
s="Graphic LCD"
```

```
FontSet F1T           ' Selects F1T
GLcd(15, 0), n        ' Writes n with F1
GLcd(15, 7), s        ' Writes w with F1
```

```
FontSet F0T           ' Selects F0T
GLcd(15, 1), "T6963c" ' Writes txt with F0
```

```
$Included "C:\FastAVR\F0T.bas" ' Here is 6x8 font definition
$Included "C:\FastAVR\F1T.bas" ' Here is 8x8 font definition
```

*Related Topics:*

GLcd

Tlcd

### 6.4.6. Gcls

*Description:*

Clears the graphic area on Graphic LCD.

*Syntax:*

**Gcls**

*Example:*

```
Gcls ' Graphic area is now cleared
```

### 6.4.7. GCommand

*Description:*

Directly controls T6963C graphic LCD controller. Used for several settings.

*Syntax:*

**GCommand var**

*Remarks:*

**var** appropriate value to set needed command according to tabel:

Graphic Mode Set:

**&h80** Logycally OR of Text with Graphics  
**&h81** Logycally XOR of Text with Graphics  
**&h83** Logycally AND of Text with Graphics  
**&h84** Text only, with Attribute data in Graphic Area  
**&h90** Display OFF  
**&h92** Text Cursor ON, Blink OFF  
**&h93** Text Cursor ON, Blink ON  
**&h94** Text ON, Graphic OFF  
**&h98** Text OFF, Graphic ON  
**&h9a** Text ON, Graphic ON

Text Cursor on Text Page Shape:

**&ha0** 1 line Cursor  
**&ha1** 2 line Cursor  
**&ha2** 3 line Cursor  
**&ha3** 4 line Cursor  
**&ha4** 5 line Cursor  
**&ha5** 6 line Cursor  
**&ha6** 7 line Cursor  
**&ha7** 8 line Cursor

Text Page and Cursor must be turned ON and Cursor shape defined with GCommand!

*Example:*

```
GCommand &h80 ' OR with Txt and Grph
GCommand &h98 ' turn Txt OFF, Grp ON
```

### 6.4.8. GCursor

*Description:*

Sets the shape of Text cursor on Text Page.

*Syntax:*

**GCursor varX, varY**

*Remarks:*

**varX** X coordinate in Characters (Columns)

**varY** Y coordinate in Lines

Text Page and Cursor must be turned ON and Cursor shape defined with `GCommand!`

*Example:*

```
GCursor 5, 2 ' Cursor is positioned
```

*Related Topics:*

[GCommand](#)

### 6.4.9. General

User can find a lot of LCD graphic modules based on Toshiba's T6963C graphic controller. Dimensions runs from 128x64 pix to 256x128 pix.

Generally they have Text page and Graphic page, both organized in 6 or 8 pix wide columns, depends on pin FS (Font Select). This pin MUST be fixed in the project! User can use Graphic, Text or both together. Text screen coordinates are in characters, while Graphic page coordinates are in pixels, starting in upper left corner (0,0). Some graphics X coordinates are in Columns, while Y are in pixels.

User can select from 6x8 and 8x8 font driving pin FS (hard wired). Unfortunately they are the same font with large interspace in case of 8x8. Writing on Text page is as with any standard alphanumeric LCD using its own built-in character generator.

Useful links:

<http://doc.semicon.toshiba.co.jp/noseek/us/td/03frame.htm>

[http://ourworld.compuserve.com/homepages/steve\\_lawther/t6963c.pdf](http://ourworld.compuserve.com/homepages/steve_lawther/t6963c.pdf)

<http://202.76.113.1/varitronix/htm/product.htm>

<http://www.hantronix.com/index.html>

### 6.4.10. GLcd

*Description:*

Writes text on graphic LCD's Graphic page. This mode uses soft characters generator in Flash table. User can edit Fonts using FastLCD.

FS pin setting MUST be on 1 for 6 pix Column wide or 0 for 8 pix column.

*Syntax:*

```
GLcd(varC, varL), var
```

*Remarks:*

**varC** Starting X coordinate in columns

**varL** Pixel to write in

**var** num, string, string constant or hex to write

X coordinates are in Columns, Y in Pixels!

Font MUST be set (`FontSet`) prior to using `GLcd!`

If You wish to show just a few words, maybe `ImgSet` is better (shorter) solution (word is made as an Image)!

If `$LeadChar` is defined then result will be right justified with Leading Chars as defined. Also, if `Format()` is defined then optional decimal point will be inserted!

*Example:*

```
GLcd(0, 0 ), n      ' Writes num variable
GLcd(1, 10), s     ' Writes string var
GLcd(2, 30), "This is T6963c" ' Writes string
GLcd(3, 60), Chr(61) ' Writes letter A
GLcd(4, 90), Hex(61) ' Writes Hex string
```

*Related Topics:*

**FS pin configuration**

FontSet

TLcd

### 6.4.11. GLcdInit

*Description:*

Initializes the Graphic LCD display

*Syntax:*

**GLcdInit**

*Example:*

**GLcdInit**

*Remarks:*

`$GLCD` and `$GCtrl` must be setup prior to using `GLcdInit`.

At initial power on or anytime the graphic LCD is powered down, `GLcdInit` should be called to initialize the LCD before using any graphic statements.

Some LCDs has theirs own internal RESET, for others user MUST generate RESET (active LOW) before Calling `GLcdInit!`

### 6.4.12. GRead

*Description:*

Reads a byte from the graphic LCD at selected Column and Y on the Graphic page.

*Syntax:*

**Var = GRead(varX, varL)**

*Remarks:*

**varC** X coordinate in columns

**varY** Y coordinate

**var** is assigned the value read

This is the graphic controllers native Read function.

X coordinates are in Columns, not in Pixels!

*Example:*

```
n = GRead(17, 2) ' Data from Column=17 on Y=2 will be Read into n.
```

*Related Topics:*

[GWrite](#)

### 6.4.13. GrpAreaSet

*Description:*

Sets the Graphic Page width in Columns.

*Syntax:*

```
GrpAreaSet col
```

*Remarks:*

**col** width of Graphic page

Graphic page can be wider then LCD visible area!

*Example:*

```
GrpAreaSet 20 ' Graphic page is 20 columns wide
```

*Related Topics:*

[TxtAreaSet](#)

[TxtHomeSet](#)

[GrpHomeSet](#)

### 6.4.14. GrpHomeSet

*Description:*

Sets the Graphic Page origin.

*Syntax:*

```
GrpHomeSet adr
```

*Remarks:*

**adr** address of Graphic page

*Example:*

```
GrpHomeSet &h0200 ' Graphic page is at &h0200 of T6963C RAM
```

*Related Topics:*

[TxtAreaSet](#)

[TxtHomeSet](#)

[GrpAreaSet](#)

### 6.4.15. GWrite

*Description:*

Writes a byte at selected Column and Y on the Graphic page.

*Syntax:*

```
GWrite(varX, varL), var
```

*Remarks:*

**varX** X coordinate, normally between 0 and 127

**varL** Line, between 0 and 7

**var** to be written to desired position.

This is the graphic controllers native Write function.

X coordinates are in Columns not in Pixels!

*Example:*

```
GWrite(17, 2), 15 ' Four pixels will be written to x=17 on the Line 2.
```

*Related Topics:*

GRead

### 6.4.16. ImgSet

*Description:*

Displays an Image or a part of ImageArray on the graphic LCD at selected Column and Y.

FS pin setting MUST be on 1 for 6 pix Column wide or 0 for 8 pix column.

*Syntax:*

```
ImgSet(varC, varY), NameOfImgTable
```

Or, if You wat to display a element of an ImageArray:

(Image must be saved as ImageArray, when edited using FastLCD utility!)

```
ImgSet(varC, varY, var), NameOfImgTable
```

*Remarks:*

**varC** coordinate in Column

**varY** Y coordinate (in Pix)

**var** which part of Image, (index in ImageArray)

**NameOfImgTable** Table in Flash that contains the bit image.

X coordinates are in Columnc not in Pixels!

**NameOfImgTable** must be declared first and added into source (\$Included)!

Images can be edited with FastLCD image editor which can save Images in **bas** format.

The saved image is then ready to be included in the source program!

*Example:*

```
Dim Img0 As Flash Byte
```

```
Dim Img1 As Flash Byte
```

```

ImgSet(5, 12), Img1  ' Image Img1 will be copied to location

$Included "C:\FastAVR\Img0.bas"  ' Img0 bit image definition
$Included "C:\FastAVR\Img1.bas"  ' Img1 bit image definition

```

#### Second syntax:

Using ImageArray, a large letters, Icons or Sprites can be displayed, all saved in a single Image!  
Any part of this Image is accessible by its index, yea - this means animations!



#### Example:

```

Dim Sclk1616HD As Flash Byte
ImgSet(15, 2, 1), Sclk1616HD  ' SandClock with index 1, second sub-Image will be
displayed

```

```

$Included "C:\FastAVR\Sclk1616HD.bas"  ' SandClock definition

```

#### Related Topics:

GLcd

## 6.4.17. Inverse

#### Description:

Inverses specified area on the screen.

#### Syntax:

```

Inverse(varX, varY, varX1, varL1)

```

#### Remarks:

**varX** LeftMost X coordinate of area, between 0 and NofColumns

**varL** TopMost coordinate, between 0 and Ymax

**varX1** number of columns to Inverse

**varL1** number of lines (pixels) to Inverse

X coordinates are in Columns not in Pixels!

#### Example:

```

Inverse(15, 1, 6, 40)  ' Specified area will be Inversed

```

#### Related Topics:

Fill

## 6.4.18. Line

### *Description:*

Draws or Clears a Line of any angle.

### *Syntax:*

```
Line(varX, varY, varX1, varY1), 0|1
```

### *Remarks:*

**varX** X coordinate of start pixel

**varY** Y coordinate of start pixel

**varX1** X coordinate of end pixel

**varY1** Y coordinate of end pixel

0|1 0 will Clear Line, 1 will Draw Line

### *Example:*

```
Line(0, 0, 239, 127), 1 ' Diagonal Line on 240x128 pix LCD
```

### *Related Topics:*

[LineH](#)

[LineV](#)

[Pset](#)

[Circle](#)

[Box](#)

## 6.4.19. LineH

### *Description:*

Draws or Clears a Horizontal Line.

FS pin setting MUST be on 1 for 6 pix Column wide or 0 for 8 pix column.

### *Syntax:*

```
LineH(varX, varY, varX1), 0|1
```

### *Remarks:*

**varX** X coordinate of LeftMost pixel in Line

**varY** Y coordinate of Line

**varX1** X coordinate of RightMost pixel in Line

0|1 0 will Clear Line, 1 will Draw Line

**varX1** must be greater than **varX**.

### *Example:*

```
LineH(15, 20, 120), 1 ' Line will be Drawn from X=15 to 120, at y=20
```

### *Related Topics:*

[LineV](#)

## 6.4.20. LineV

### Description:

Draws or Clears a Vertical Line.

FS pin setting MUST be on 1 for 6 pix Column wide or 0 for 8 pix column.

### Syntax:

```
LineV(varX, varY, varY1), 0|1
```

### Remarks:

**varX** X coordinate of Line

**varY** Y coordinate of TopMost pixel in Line

**varY1** Y coordinate of BottomMost pixel in Line

0|1 0 will Clear Line, 1 will Draw Line

**varY1** must be greater than **varY**.

### Example:

```
LineV(15, 20, 60), 1 ' Vertical Line will be Drawn from y=20 to 60, at x=15
```

### Related Topics:

[LineH](#)

## 6.4.21. Point

### Description:

Tests if specified Pixel location is Set or Reset.

### Syntax:

```
Var = Point(varX, varY)
```

### Remarks:

**varX** X coordinate

**varY** Y coordinate

**var** is assigned the result, 0 if pixel is Reset, 1 if Pixel is Set

### Example:

```
n = Point(15, 2) ' If n>0 that Pixel is Set
```

### Related Topics:

[PSet](#)

### 6.4.22. Pset

*Description:*

Sets or Resets an individual Pixel at the desired position.  
FS pin setting MUST be on 1 for 6 pix Column wide or 0 for 8 pix column.

*Syntax:*

```
Pset (varX, varY), 0|1
```

*Remarks:*

**varX** X coordinate

**varY** Y coordinate

0|1 0 will Reset pixel, 1 will Set pixel, (color)

*Example:*

```
Pset(15, 20), 1 ' Pixel at coordinates 15, 20 will be Set
```

*Related Topics:*

[Point](#)

[LineH](#)

[LineV](#)

### 6.4.23. Tcls

*Description:*

Clears the text area on Graphic LCD.

*Syntax:*

```
Tcls
```

*Example:*

```
Tcls ' Just text area is now cleared
```

*Related Topics:*

[Fill](#)

### 6.4.24. TLcd

*Description:*

Writes text on graphic LCD's Text page defined on `TxtHomeSet`. This mode uses build-in characters generator.  
User can select between 6x8 font (FS=1) and 8x8 font (FS=0).

*Syntax:*

```
TLcd(varC, varL), var
```

*Remarks:*

**varC** Starting X coordinate in columns

**varL** Line to write in

**var** num, string, string constant or hex to write

X and Y coordinates are in Columns and Lines, not in Pixels!

If `$LeadChar` is defined then result will be right justified with Leading Chars as defined. Also, if `Format()` is defined then optional decimal point will be inserted!

*Example:*

```
TLcd(0, 0), "This is T6963C" ' Writes string on upper Line
```

*Related Topics:*

[FS pin configuration](#)

[GCursor](#)

[GCommand](#)

### 6.4.25. TxtAreaSet

*Description:*

Sets the Text Page width in Columns.

*Syntax:*

```
TxtAreaSet col
```

*Remarks:*

`col` width of Text page

Text page can be wider then LCD visible area!

*Example:*

```
TxtAreaSet 20 ' Text page is 20 columns wide
```

*Related Topics:*

[TxtHomeSet](#)

[GrpHomeSet](#)

[GrpAreaSet](#)

### 6.4.26. TxtHomeSet

*Description:*

Sets the Text Page origin. Can be anywhere in the T6963C RAM.

*Syntax:*

```
TxtHomeSet adr
```

*Remarks:*

`adr` address of Text page

*Example:*

```
TxtHomeSet &h0000 ' Txt page is at the begining of T6963C RAM
```

*Related Topics:*[TxtAreaSet](#)[GrpHomeSet](#)[GrpAreaSet](#)

## 6.5. 1WWrite

*Description:*

1WReset, 1WRead and 1WWrite are the commands used to communicate with Dallas 1 Wire devices.

*Syntax:*

```
1WWrite [n,] var|exp|func
```

or block version

```
1WWrite [n,] var1, m
```

*Remarks:*

1WWrite writes a variable to the bus (var), the result of an entire expression (exp) or a function result (func)

n is index if more than one 1Wire bus are used, 0 is default for single 1Wire bus or first 1Wire bus!

*Example:*

```
1wwrite &hcc; &h44      ' writing on first 1Wire bus
1wwrite 2, &hcc; &h44  ' writing on 1Wire bus with index 2
```

*Related topics:*[\\$1Wire](#)[1WReset](#)[1WRead](#)

## 6.6. 1WReset

*Description:*

1WReset, 1WRead and 1WWrite are the commands used to communicate with Dallas 1 Wire devices.

*Syntax:*

```
var=1WReset [n]
```

or

```
1WReset [n]
```

*Remarks:*

1WReset resets the bus and returns the status in var (byte), 0 = there is no 1Wire devices on bus!

n is index if more than one 1Wire bus are used, 0 is default for single 1Wire bus or first 1Wire bus!

*Example:*

```
a=1wreset, 1 ' reseting secont (index 1) 1Wire bus
```

*Related topics:*

[\\$1Wire](#)

[1WRead](#)

[1WWrite](#)

## 6.7. 1WRead

*Description:*

1WReset, 1WRead and 1WWrite are the commands used to communicate with Dallas 1 Wire devices.

*Syntax:*

```
var=1WRead [n]
```

or block version

```
1WRead [n,] var1, m
```

*Remarks:*

1WRead reads from the 1WIRE device and stores the result in var

Second syntax is special block read, m bytes will be read and stored from var1 up in SRAM. var1 MUST be global!

n is index if more than one 1Wire bus are used, 0 is default for single 1Wire bus or first 1Wire bus!

*Example:*

```
$1wire=PORTD.3
```

```
lwread n, 8 ' block lwread, n must be global
x=lwread ' lwread in variable x
```

*Related topics:*

[\\$1Wire](#)

[1WReset](#)

[1WWrite](#)

## 6.8. Abs

*Description:*

Returns the absolute value of its argument.

*Syntax:*

```
var=Abs(numeric expression)
```

*Remarks:*

**var** will contain the positive value of the signed **numeric expression**. (integer or Long)

*Example:*

```
n=-15      'n contains -15
n=Asc(n)   'n will contain 15
```

## 6.9. Ac

*Description:*

Defines the type of Analog Comparator Interrupt.

*Syntax:*

```
Ac type
```

*Remarks:*

type can be:

- Rising
- Falling
- Toggle

Attention! Default settings is Toggle!

*Example:*

```
Ac Rising      ' Aci will be triggered on the rising edge.
```

*Related topics:*

[Start](#)

[Stop](#)

[Enable](#)

[Disable](#)

## 6.10. Acos

*Description:*

Calculates Inverse Cosine.

*Syntax:*

```
var=Acos(numeric expression)
```

*Remarks:*

**var** receives a **Acos** of **numeric expression**  
**numeric expression** must be positive

Acos can return value in Degrees or Radians depends on \$Angles Metastatement!

*Example:*

```
Dim n As Float

n=Acos(0.5)      'n=60, (if $Angles=Deegrees)
```

*Related topics:*

[Sin](#)

[Cos](#)

[Tan](#)

[Asin](#)

[Atan](#)

## 6.11. Adc

*Description:*

Reads the converted analog value from the ADC (valid only for AVR devices with built in ADC).

*Syntax:*

```
var=ADC(channel)      ' 10 bits conversion
var=ADC8(channel)    ' 8 bits conversion
```

*Remarks:*

channel is the number of the ADC channel (mux).

var is a variable that stores the ADC value read.

Adc8(ch) returns 8 bit value.

Note that ADC must be started first!

*Example:*

```
Start Adc
n=Adc8(i)      ' n = 8 bit ADC value
w=Adc(i)      ' W = 10 bit ADC value
```

*Related topics:*

[Start](#)

[Stop](#)

## 6.12. Asc

*Description:*

Returns the ASCII code of a character in a string argument.

*Syntax:*

```
var=Asc(string or string constant [, numeric expression])
```

*Remarks:*

Returns the ASCII code of the first character or any character that the second optional **numeric expression** is pointing to.

*Example:*

```
s="A"
n=Asc(s) 'n will contain 65
s="12345"
n=Asc(s, 3) 'n will contain 51 (ASCII code for "4")
```

*Related topics:*

[Chr](#)

## 6.13. Asin

*Description:*

Calculates Inverse Sine.

*Syntax:*

```
var=Asin(numeric expression)
```

*Remarks:*

var **receives a Asin of** numeric expression  
numeric expression

Asin can return value in Degrees or Radians depends on \$Angles Metastatement!

*Example:*

```
Dim n As Float
n=Asin(0.5) 'n=30, (if $Angles=Deegrees)
```

*Related topics:*

[Sin](#)

[Cos](#)

[Tan](#)

[Asin](#)

[Acos](#)

[Atan](#)

## 6.14. Atan

### Description:

Calculates Inverse Tangens.

### Syntax:

```
var=Atan(numeric expression)
```

### Remarks:

var receives a **Atan** of numeric expression  
 numeric expression

Atan can return value in Degrees or Radians depends on \$Angles Metastatement!

### Example:

```
Dim f1 As Float
```

```
f1=ATan(1) 'f1=45, (if $Angles=Deegrees)
```

### Related topics:

[Sin](#)

[Cos](#)

[Tan](#)

[Asin](#)

[Acos](#)

## 6.15. Atan2

### Description:

Returns the angle from the X axis to a Point (x,y) in units defined in \$Angles (default: Radians)

### Syntax:

```
var=Atan2(x, y)
```

Atan2 can return value in Degrees or Radians depends on \$Angles Metastatement!

### Remarks:

var receives an angle **Atan2**

y is a number argument cooresponding to Y of point (y,x)

x is a number argument cooresponding to X of point (y,x)

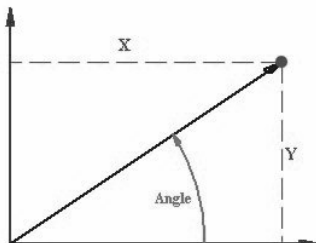

*Example:*

```
Dim f1 As Float

f1=ATan2(6,6)      'f1=45, (if $Angles=Deegrees)
```

*Related topics:*[Sin](#)[Cos](#)[Tan](#)[Asin](#)[Acos](#)[Atan](#)

## 6.16. Baud

*Description:*

Overrides the \$Baud command.

*Syntax:*

```
Baud = const [, Parity, DataBits, StopBits]
Baud2 = const           ' for second UART
```

*Remarks:*

const is the baud rate number - standard values:  
1200, 2400, 4800, 9600, 19200, 38400, 56600,76800,115200  
but can be any value

Parity N, O, E, M or S (if Parity is set then DataBits must be 9!)

DataBits 8 or 9

StopBits 1 or 2 (in case of 9 DataBits, must be only 1 StopBit)

*Example:*

```
Baud=1200      'default = N, 8, 1
Baud2=9600     'default = N, 8, 1
```

*Related topics:*[Print](#)[PrintBin](#)[Start](#)[Stop](#)[Input](#)[InputBin](#)

## 6.17. Bcd

*Description:*

Returns the BCD value of a variable.

*Syntax:*

```
var1=Bcd(var2)
```

*Remarks:*

var1 is the target variable.

var2 is the source variable.

*Example:*

```
n=18
m=Bcd(n)      ' m=&h18
```

*Related topics:*

[FromBcd](#)

[Chr](#)

## 6.18. BitWait

*Description:*

Waits for a specified `PINx.bit` to become 1 or 0.

*Syntax:*

```
BitWait name 1|0
BitWait PINx.pin 1|0
```

*Remarks:*

name is the name of `PORT.pin` defined with `$Def`.

`PINx.pin` is name of the physical pin.

Note: BitWait waits for specified bit value until this value is reached!

*Example:*

```
$Def sig=PORTD.5

BitWait sig, 1      'the program waits for 1
BitWait PIND.4, 0   'the program waits for 0
```

## 6.19. Case

Select

## 6.20. Chr

*Description:*

Converts ASCII code into the corresponding ASCII character.

*Syntax:*

```
var1=Chr (var2)
```

*Remarks:*

var1 is the target variable.

var2 is the source variable.

*Example:*

```
n=65
Print Chr (n)           'Displays A
```

*Related topics:*

Asc

BCD

## 6.21. Const

*Description:*

Declares a constant.

*Syntax:*

```
Const name=NumConst [, simple expression]
```

*Remarks:*

name is a name of your choice.

NumConst is the value of the constant.

*Example:*

```
Const True=1, False=0

Const time=250
Const uppr=time+50   ' uppr is 300
Const s="FastAVR"   ' String constants also
```

*Related topics:*

\$Def

## 6.22. Cls

*Description:*

Clears the LCD and sets the cursor to home position.

*Syntax:*

```
Cls
```

*Example:*

```
Cls      'Clears the LCD
```

*Related topics:*

[LCD](#)

[Locate](#)

[Cursor](#)

[Display](#)

## 6.23. Cos

*Description:*

Returns the trigonometric Cosine of its argument.

*Syntax:*

```
var=Cos(numeric expression)
```

*Remarks:*

var type Float receives a Cosine of numeric expression

numeric expression can be in Radians or Deegrees, depending on \$Angles metastatement!

*Example:*

```
Dim n As Byte  
Dim f1 As Float
```

```
n=30          ' assuming $Angles=Degrees  
f1=Cos(n)     ' f1=0.8660254
```

*Related topics:*

[Sin](#)

[Tan](#)

[Asin](#)

[Acos](#)

[Atan](#)

## 6.24. Cosh

*Description:*

Returns the Cosine Hiperbolicus of its argument.

*Syntax:*

```
var=Cosh(numeric expression)
```

*Remarks:*

var type Float receives a Cosh of numeric expression  
numeric expression

*Example:*

```
Dim f1 As Float
```

```
f1=Cosh(5)      'f1=74.20995
```

*Related topics:*

[Sinh](#)

[Tanh](#)

## 6.25. CPeek

*Description:*

Returns a Byte from program memory (flash).

*Syntax:*

```
var=CPeek(adr)
```

*Remarks:*

var The variable that is assigned.  
adr The address in program memory.

*Example:*

```
m=CPeek(n)
```

*Related topics:*

[Poke](#)

[Peek](#)

## 6.26. Crc8

*Description:*

Calculates 8bit crc value in SRAM, starting at adr of var.

*Syntax:*

```
var1=Crc8(var, n)
```

*Remarks:*

var1 is the calculated Crc value.

var itself is the starting address in SRAM (If here is variable, then address of this variable is used.

n is the number of bytes to calculate Crc.

*Example:*

```
Dim n(8) As Byte
```

```
Dim Crc As Byte
```

```
Crc=Crc8(n, 8)      'calculate 8bit crc 8bytes from n up
```

```
Crc=Crc8(VarPtr(n)+3 ,8)      'we are adding here 3 to the address of variable n
```

## 6.27. Cursor

*Description:*

Controls the LCD cursor behavior.

*Syntax:*

```
Cursor On|Off|Blink|NoBlink
```

*Remarks:*

Default is Off and NoBlink

*Example:*

```
Cursor Off      'Cursor is not visible
```

```
Cursor On      'Cursor is visible
```

```
Cursor Blink   'Cursor is blinking
```

*Related topics:*

[LCD](#)

[Locate](#)

[Cls](#)

[Display](#)

## 6.28. Data

[Look at Dim](#)

## 6.29. Declare

*Description:*

Explicitly declares a user Subroutine or Function.

*Syntax:*

```
Declare Sub SubName([par1 As type] [, par2 As Type])
```

```
Declare Function FuncName([par1 As type] [, par2 As type]) As rType
Declare Interrupt IntType()
```

**Remarks:**

SubName is a subroutine name of your choice.

FuncName is a function name of your choice.

parx is a name of passing parameters to the Sub or Function

rType is type of the returned value of function, (Byte, Integer, Word or Long)

IntType is the type of Interrupt (look at [Interrupts](#))

Very important: Declared .... belongs to the header of the program, before any other normal statements!

Parameter's names used in Declare statements MUST be the same as names in the actual Subs or Functions!

**Example:**

```
Declare Sub Test(n As Byte)           'declares a Sub Test
Declare Function Test1(n As Byte) As Byte 'declares a Function Test1
Declare Interrupt Ovfl1()             'declares a Timer1 Overflow Interrupt routine
```

## 6.30. Decr

**Description:**

Decrements var by 1

**Syntax:**

```
Decr var
```

**Remarks:**

var is a numeric variable.

**Example:**

```
Decr a 'a=a-1
```

**Related topics:**

[Incr](#)

## 6.31. DefLcdChar

**Description:**

Defines one of eight LCD special characters.

**Syntax:**

```
DefLcdChar n, byte1, byte2, byte3, byte4, byte5, byte6, byte7, byte8
```

**Remarks:**

n number of special character (0-7)

bytex 8 bytes defining special character

Graphic editor for LCD characters will automatically insert this statement at current cursor position, but user has to

modify **n** from 0 to range 0-7!

*Example:*

```
DefLcdChar 0, &h08, &h10, &h1C, &h00, &h00, &h04, &h18, &h00
Lcd Chr(0)
```

## 6.32. Dim

*Description:*

Declares and dimensions arrays and variables and their types.

*Syntax:*

```
Dim VarName As [Xram|Flash] Type [At &h1000]
Dim VarName(n) As Type
```

*Remarks:*

VarName is the variable name.

type is one of the following variable types:

- Bit uses one of 16 reserved bits (R2 and R3)
- Byte uses one byte of RAM memory
- Integer uses one two of RAM memory
- Word uses two bytes of RAM memory
- Long uses four bytes of RAM memory
- Float uses four bytes of RAM memory

String \* Length uses "length" Bytes of RAM memory, plus one more for termination of the string.

Length is the number of string variable elements(characters).

n is the number of array elements

Xram var will be placed in external RAM at address specified after **At** in hex.

Flash constants will be placed in Flash at address specified by VarName.

Very important: Dim .... belongs to the header of the program, just after Declares and BEFORE any other normal statements!

*Attention:*

Data and Lookup keywords were removed because this mechanism didn't allow the whole range of data types to be built!

Here is the new implementation for table use.

```
Dim TableName As Flash Type
```

TableName is table of specific type of constant in Flash.

User can fill table:

```
TableName = 11,22,33,44,
55,66,77,88
```

User can fill also a table of strings:

```
TableName = London, Newyork, Paris, Roma,
Berlin, Ljubljana, Madrid, Amsterdam
```

As you can see, data can continue in the next line and stops where the comma is missing!

Access to table:

```
var=TableName(index)
```

### Tables in Flash MUST be initialized at the END of Program!

#### Example:

```
Dim a As Byte           'global byte variable named a
Dim w As Word          'global word variable named w
Dim f As Float         'global word variable named w
Dim db(10) As Byte     'global array of ten bytes named n
Dim s1 As String * 8   'global string variable named s1, length must be specified
Dim s2 As String * 9   'global string variable named s2, length must be specified
Dim a As Xram Byte     'global byte variable named a in Xram
Dim w(16) As Flash Word 'global word constant in Flash (table), number of elements could be
also declared
Dim s As Flash String  'global string constants in Flash (table), without strings length
```

#### Array of Strings Example:

```
Dim MyString(10) As String * 7 ' ten Strings seven characters each (total 8)

MyString=(" ")                  ' will init all array elements to " "
MyString=("123", "ABC", " ")    ' will init first three elements
```

Arrays, Bits and Strings can not be Local variables!

#### Related topics:

[Local](#)

## 6.33. Disable

#### Description:

Disables Global Interrupts and/or individual Interrupts.

#### Syntax:

```
Disable Interrupts
Disable int
```

#### Remarks:

int is a valid Interrupt type

#### [Look at Interrupts](#)

#### Example:

```
Disable Interrupts 'disables Interrupts (Global)
Disable Ovf1       'from now on Ovf1 is disabled
```

#### Related topics:

[Enable](#)

[Interrupts](#)

## 6.34. Display

*Description:*

Controls the LCD ON or OFF.

*Syntax:*

```
Display On|Off
```

*Remarks:*

Default is On.

*Example:*

```
Display On      'Display is ON
Display Off     'Display is OFF
```

*Related topics:*

[LCD](#)

[Locate](#)

[Cls](#)

[Display](#)

## 6.35. DegToRad

*Description:*

Converts Deegrees to Radians.

*Syntax:*

```
var=DegToRad(var1)
```

*Remarks:*

var The var that is assigned Radians.

var1 The Deegrees to convert.

*Example:*

```
Dim n As Byte
Dim f1 As Float, f2 As Float

f1=180
f2=DegToRad(f1)    'f2=3.141593
```

*Related topics:*

[RadToDeg](#)

[\\$Angles](#)

## 6.36. Do

### *Description:*

Defines a loop of statements that are executed while a certain condition is true. Because test for condition is at the end of the loop, the loop itself will be executed at least once!

### *Syntax:*

```
Do
    statements
Exit Do           'you can EXIT from the loop at any time
Loop [While condition]
```

### *Remarks:*

condition The Numeric or string expression that evaluates to True or False.

Statements within loop are executed at least one time, because test for condition is at the end of loop.

Useful for never ending loop.

### *Example:*

```
Dim i As Byte

Do           ' never ending loop
    For i=0 To 5
        Print Adc8(i)
        Waitms 250
    Next
Loop
```

### *Related topics:*

[While-Wend](#)

## 6.37. DTMF

### *Description:*

Generates DTMF tone.

### *Syntax:*

```
DTMF (var)
```

### *Remarks:*

var, expression or constant must be between 0 and 15

Key var and Tones Table

0	0
1	1
2	2
3	3
4	4
5	5
6	6
7	7
8	8

```

9 9
10 A
11 B
12 C
13 D
14 *
15 #

```

**ATTENTION!**

Timer1 and OVF1 interrupt are used. User can NOT use this timer and interrupt for other purposes!

User MUST enable global interrupts

```
Enable Interrupts
```

and Ovf0 interrupt

```
Enable Ovf1
```

Note also that some filtering is necessary at the output (pin OC1)!

*Example:*

```
Enable Interrupts 'user must enable interrupts
```

```
DTMF(5)
```

*Related topics:*

[\\$DTMF](#)

## 6.38. Enable

*Description:*

Enables Global Interrupts and/or individual Interrupts.

*Syntax:*

```
Enable Interrupts
Enable int
```

int is a valid Interrupt type

*Remarks:*

Check Interrupt types for each microcontroller used!

*Example:*

```
Enable Interrupts 'enables global Interrupts
Enable Ovf1      'enables Timer1 Ovf1 Interrupt
```

*Related topics:*

[Disable  
Interrupts](#)

## 6.39. End

*Description:*

Ends program execution.

*Syntax:*

End

*Remarks:*

It is not necessary to use this statement if You are using a never-ending loop.

## 6.40. Exit

[Sub](#)

[Function](#)

[For-Next](#)

[Do](#)

[While](#)

## 6.41. Exp

*Description:*

Calculates a base number raised to a power.

*Syntax:*

var=Exp(numeric expression)

*Remarks:*

var receives a Exp of numeric expression  
numeric expression

*Example:*

```
Dim n As Float
```

```
n=Exp(3.45) 'n=3.150039E+01
```

*Related topics:*

[Log](#)

[Log10](#)

[Pow](#)

## 6.42. Find8

### Description:

Finds a value in a Table of bytes.

### Syntax:

```
var=Find8(var1, TableName)
```

```
var    returned value
var1   search value
TableName Table which will be searched,
```

### Remarks:

Function returns position of searched element or 0 if there is no such element!

Table must be declared as data in flash with number of elements and initialized (at the end of program).

### Example:

```
Dim n As Byte
Dim Table(9) As Flash Byte ' number of elements MUST be also declared

n=Find(55, Table)          ' n will be 5

Table = 11,22,33,44,55,66,77,88,99 'table of 9 elements
```

### Related topics:

[Find16](#)

## 6.43. Find16

### Description:

Finds a value in Table of Words or Integers.

### Syntax:

```
var=Find16(var1, TableName)
```

```
var    returned value
var1   search value
TableName Table which will be searched
```

### Remarks:

Function returns position of searched element or 0 if there is no such element!

Table must be declared as data in flash with number of elements and initialized (at the end of program).

### Example:

```
Dim n As Word
Dim Table1(9) As Flash Word ' number of elements MUST be also declared

n=Find16(5555, Table1)      ' n will be 5

Table1 = 1111,2222,3333,4444,5555,6666,7777,8888,9999 'table of 9 elements
```

### Related topics:

[Find8](#)

## 6.44. For

### Description:

Defines a loop of program statements whose execution is controlled by a loop counter.

### Syntax:

```
For counter=start To stop [Step [-] StepValue]
    statements
[Exit For] 'you can EXIT from the loop at any time
Next
```

### Remarks:

counter numeric variable - **Byte, Integer or Word!**  
start numeric expression specifying initial value for counter  
stop numeric expression giving the last counter value  
stepvalue numeric constant, default is 1, can be negative for decrement

**Attention! Counter MUST be Byte, Integer or Word!**

### Example:

```
Dim i As Byte

Do
    For i=0 To 5
        Print Adc8(i)
        WaitMs 250
    Next
Loop
```

### Related topics:

[Do-Loop](#)

[While-Wend](#)

## 6.45. Format

### Description:

Defines Format for Print, Lcd, Tlcd, Glcd and Str().

### Syntax:

```
Format (Int|Scientific,Frac)
```

### Remarks:

Int Number of Integer numbers, - for Float max 10, min 1. Scientific (or 0) for scientific format, -x.xxxxxE+yy  
Frac Number of Fractal numbers, - for Float min 1.

Floating point numbers can be presented in normal: 6532.818                   'Format(4,3)

or in Scientific Format: 6.532818E+03           'Format(Scientific,7)

*Scientific format is Default for Float numbers!*

Floating point numbers of Single precision has max 7 nums but can lay between 10E+38 and 10E-38.  
The last (7th) num is already rounded!

Note that Format MUST be first mentioned under metastatement \$LeadChar (for Byte, Integer, Word and Long - not for Float)!

Numbers are RIGHT justified!

*Example:*

```
Dim n As Byte, x As Word, f As Float
Dim s As String*5
```

```
n=65: w=1234: f=-1.234E+02
```

```
Format(3,0)
Print n
'output will be 065 (assume that "0" is defined as LeadChar)
```

```
Format(4,1)
Print w
'output will be 0123.4 (assume that "0" is defined as LeadChar)
```

```
Format(5,3)
Print f
'output will be -00123.400 (assume that "0" is defined as LeadChar)
```

```
Format(Scientific,3)
Print f
'output will be -1.234E+02
```

*Related topics:*

[\\$LeadChar](#)

## 6.46. Fract

*Description:*

Returns Fractional part of Float argument as Float.

*Syntax:*

```
var=Fract(numeric expression)
```

*Remarks:*

var receives a Fractional part of numeric expression  
numeric expression

*Example:*

```
Dim n As Float
```

```
n=Fract(3.45) 'n=0.45
```

*Related topics:*

[Int](#)

## 6.47. FromBcd

*Description:*

Calculates value from BCD format.

*Syntax:*

```
var1=FromBcd(var2)
```

*Remarks:*

var1 is the target variable.

var2 is the source BCD variable.

*Example:*

```
m=FromBcd(n)
```

*Related topics:*

[BCD](#)

## 6.48. Function

*Description:*

Defines a Function procedure.

*Syntax:*

```
Function NameOfFunc(parameters list) As Type
```

*Remarks:*

NameOfFunc is the name of Function

parameters list is the name and type of parameters, comma delimited (can not be Bit) - MUST has the same names as is in theirs Declare statements!

As Type is type of returned value (Byte, Integer, Word, Long or Float)

Function must first be declared with Declare keyword.

*Example:*

```
Declare Function Mul(a As Byte, b As Byte) As Byte
Dim n As Byte
```

```
n=Mul(5, 7)      'n=35
```

```
'////////////////////////////////////
Function Mul(a As Byte, b As Byte) As Byte
```

```
Return a*b
[Exit Function]      ' optionally exit from Function
End Function        ' end of Function
```

*Related topics:*

[Declare](#)

[Return](#)

[Sub](#)

## 6.49. GoTo

### Description:

Transfers program execution to the statement identified by a specified label.

### Syntax:

```
Goto label
```

### Remarks:

label is a line identifier indicating where to jump

### Example:

```
Point:          'a label must end with a colon
```

```
Goto Point
```

## 6.50. I2CRead

I2CStart

## 6.51. I2CStart

### Description:

I2CStart starts the I2C transfers.

I2CStop stops the I2C transfers

I2CRead receives a single byte through I2C bus

I2CWrite sends a single byte through I2C bus

### Syntax:

```
I2CStart adr
var1=I2CRead, Ack [, Nack]
I2CWrite var2
I2CStop
```

### Remarks:

adr The address of the I2C-device.

var1 The variable that receives the value from the I2C-device.

var2 The variable or constant to write to the I2C-device

Ack - tells that there will be more Readings

Nack - this is last Reading (MUST be present)

Dont forget pulup resistors on SDA and SCL (4k7 - 10k)!

**Notes about I2Cread:** The first call to I2Cread will issue also device address for Read (last bit is automaticaly set), last **I2Cread** command MUST be used with **Nack** option!

### Example1:

```
'reading time from Philips PCF85x3
I2cstart &ha0          'generate start
```

```

I2cwrite 2          'select second register
s=I2cread, Ack
m=I2cread, Ack
h=I2cread, Nack
I2cstop           'generate stop

```

**Example2:**

```

'//////////////////////////////////////
Sub WritePage(Padr As Word)
Local i As Byte

I2Cstart &ha0      ' 24C64 address
I2Cwrite Msb(Padr) ' write adr MSB
I2Cwrite Padr     ' write adr LSB
For i=0 To 31
    I2Cwrite buff(i) ' write data from array buff
Next
I2Cstop
WaitMs 6          ' wait to write (10 max)
End Sub

```

**Example3:**

```

'//////////////////////////////////////
Sub ReadPage(Padr As Word)
Local i As Byte, tmp As Byte

I2Cstart &ha0      ' 24C64 address
I2Cwrite Msb(Padr) ' write adr MSB
I2Cwrite Padr     ' write adr LSB

tmp=I2Cread, Ack   ' first read deefers from others
For i=0 To 31
    buff(i)=tmp    ' we read into buff array
    tmp=I2Cread, Ack
Next
tmp=I2Cread, Nack ' dummy read - we need Nack!
I2Cstop
End Sub

```

**Related topics:**[I2CStop](#)[I2CWrite](#)[I2CRead](#)

**6.52. I2CStop**I2CStart**6.53. I2CWrite**I2CStart**6.54. If***Description:*

Conditionally executes a group of statements, depending on the value of an expression(s).

*Syntax:*

```
If expression Then statement
```

or

```
If expression Then
    statements
ElseIf expression Then
    statements
.
.
Else
    statements
End If
```

*Remarks:*

While testing bit variables of any kind (bit var, port.bit or var.bit) only "=1", "=0" or nothing can be used!  
**Conditions and statements may be contained on one line or multiple lines.**  
**Instead of using many ElseIfs, Select Case may be used!**

*Example:*

```
If a>5 And a<10 Then
    Print a; " a is Between 5 and 10"
ElseIf a=5 Then
    Print a; " a is 5"
Else
    Print b; " a has other value"
End If

If a Then 'If a>0 generates extra comact code
    Print a
End If

If PINB.5 Then
    Print a
End If

If a.3 Then
    Print a
End If
```

*Related topics:*

[Select](#)

## 6.55. **Incr**

*Description:*

Increments var by 1

*Syntax:*

```
Incr var
```

*Remarks:*

var variable to increment

*Example:*

```
Incr a ' a=a+1
```

*Related topics:*

[Decr](#)

## 6.56. **InitLcd**

*Description:*

Re initialize alphanumeric LCD.

*Syntax:*

```
InitLcd
```

*Remarks:*

If LCD was turned OFF because of entering in one of the PowerDown modes it needs to be Reinitialized after waken up.

*Example:*

```
InitLcd
```

*Related topics:*

[\\$Lcd](#)

[Lcd](#)

## 6.57. InitEE

### Description:

Initialize EPROM data to be written during device programming.

### Syntax:

```
InitEE = 11, 22, 33, 44,  
        55, 66, 77, 88
```

### Remarks:

InitEE will produce a hex file named BasName.eep for EPROM programming starting at adr 0!  
Numeric constants are comma delimited and can be placed in more than one line.

### Related topics:

[ReadEE](#)

[WriteEE](#)

## 6.58. Input

### Description:

Returns the value or string from the RS-232 port.

### Syntax:

```
Input ["prompt"], var1, var2, ....  
Input2 ["prompt"], var1, var2, .... ' for second UART
```

### Remarks:

`prompt` is an optional string constant printed before the prompt character.  
`varX` is/are the variable(s) to accept the input value or a string, not for Longs!

With the built-in terminal emulator this statement makes the PC keyboard an input device.

### Example:

```
Input s  
Input n, w  
Input "n="; n; "w="; w
```

```
Input2 s
```

### Related topics:

[Print](#)

[PrintBin](#)

[InputBin](#)

## 6.59. InputBin

*Description:*

Returns a binary value(s) from the RS-232 port.

*Syntax:*

```
InputBin var1; var2;...
```

```
InputBin var, n
```

```
InputBin2 var1; var2;... ' for second UART
```

*Remarks:*

var, var1, var2 variables that receive a binary value from serial port  
n number of bytes to receive. Bytes will be stored from var up!

The number of bytes to read depends on the variable length You use, 1 for byte, 2 for integer or word.

*Example:*

```
InputBin a; w ' waits three bytes
```

```
InputBin a, 12 ' waits for 12 bytes (from a up)
```

```
InputBin2 a; w ' waits three bytes
```

*Related topics:*

[PrintBin](#)

## 6.60. Int

*Description:*

Returns Integer part of Float argument as Float.

*Syntax:*

```
var=Int (numeric expression)
```

*Remarks:*

var receives an Integer part of numeric expression  
numeric expression

*Example:*

```
Dim n As Float
```

```
n=Int (372.41855) 'n=372.0
```

*Related topics:*

[Fract](#)

## 6.61. IntX

### Description:

Defines the type of external Interrupt trigger.

### Syntax:

```
Intx type
```

### Remarks:

x interrupt number 0-7

type can be:

Rising

Falling

Low

Attention! Default settings is Low!

### Example:

```
Int0 Rising      ' Int0 will be triggered on the rising edge.
```

## 6.62. Instr

### Description:

Return the first occurrence of a specified string into another string.

### Syntax:

```
var=Instr([var1,] mainString, matchString)
```

### Remarks:

var receives position of matchString in mainString or 0 if matchString is not in mainString or any error.

var1 starting search position, can be omitted.

mainString source String (MUST be string var, not string constant)

matchString can be String Constant.

### Example:

```
Dim Name As String*15
```

```
Dim Part As Byte
```

```
Name="Mona Lisa"
```

```
Part=Instr(Name, "Li")      'Part=6
```

### Related topics:

## 6.63. Key()

*Description:*

Returns a byte in var representing a pressed key in the line or matrix keyboard!

*Syntax*

```
var=Key()
```

```
NoKey() only for line switches, waits until user releases keys.
```

*Remarks:*

var contains the pressed key, returns 0 if no key is pressed.

**Note:** If your main loop (or other loops) is very busy then calling Key must be done in EXternal interrupt routine.

*Example:*

```
a=Key()
NoKey() 'waits until user releases keys
```

*Related topics:*

[PcKey](#)

[RC5](#)

## 6.64. LCase

*Description:*

Returns an all-lowercase version of its string argument.

*Syntax:*

```
var=LCase(var1)
```

*Remarks:*

var lowercase string version of var1

var1 original string variable.

Argument MUST be single String variable!

*Example:*

```
Dim Name As String*15
Dim Part As String*10

Name="Mona Lisa"
Part=LCase(Name) 'Part="mona lisa"
```

*Related topics:*

[UCase](#)

## 6.65. Lcd

### Description:

Prints to standard ASCII LCD modules.

### Syntax:

```
Lcd var1; var2;...
Lcd Hex (var1)
```

### Remarks:

var1, var2 are vars to be printed on LCD  
Hex(var1) var1 will be printed in hexadecimal format

If \$LeadChar is defined then result will be right justified with Leading Chars as defined. Also, if Format() is defined then optional decimal point will be inserted (even with Integer variables!)

### Example:

```
Lcd "FastAVR Basic Compiler!"
Locate 2, 1: Lcd "n="
Do
  Locate 2, 3: Lcd n
  Incr n
  WaitMs 250
Loop
```

### Related topics:

[LCD](#)

[Locate](#)

[Display](#)

[Cursor](#)

[DefLcdChar](#)

[InitLcd](#)

## 6.66. Left

### Description:

Returns the leftmost n characters of a string.

### Syntax:

```
var=Left (var1, n)
```

### Remarks:

var string that Left chars are assigned.  
var1 original string (MUST be string var, not string constant).  
n number of characters to be returned from left.

### Example:

```
Dim Name As String*15
Dim Part As String*10

Name="Mona Lisa"
Part=Left (Name, 4)   'Part="Mona"
```

*Related topics:*

[Right](#)

[Mid](#)

## 6.67. Len

*Description:*

Returns the length of a string.

*Syntax:*

```
var=Len(string var)
```

*Remarks:*

var string that receives Legth in chars of string var.  
string var original string.

*Example:*

```
Name="Mona Lisa"
n=Len(Name)      'n=9
```

*Related topics:*

[Left](#)

[Right](#)

[Mid](#)

[Str](#)

## 6.68. Local

*Description:*

Declares and dimensions Local variables, seen only inside of Subs and/or Functions.

*Syntax:*

```
Local VarName As Type
```

*Remarks:*

VarName is the variable name.

type is one of the following variable types:

Byte	uses one byte of RAM memory
Integer	uses one two of RAM memory
Word	uses two bytes of RAM memory
Long	uses four bytes of RAM memory
Float	uses four bytes of RAM memory

Length is the number of string variable elements(characters).

n is the number of array elements

*Example:*

```
'////////////////////////////////////
Sub Test(n As Byte)
Local a As Byte          'local byte variable named a
```

---

```
Local w As Word          'local word variable named w
```

Body of Sub

```
End Sub
```

Arrays, Bits and Strings can not be Local variables!

*Related topics:*

[Dim](#)

## 6.69. Locate

*Description:*

Locates the position for the next character to be printed.

*Syntax:*

```
Locate row, var1  
Locate adr
```

*Remarks:*

row is a numeric constant representing the row to print in.

var1 is a requested column value

adr is an alternative absolute address for positioning on the LCD. See LCD data sheets for actual addressing!

*Example:*

```
Locate 2, 3: Lcd n      'n will be printed in second row at position 3
```

*Related topics:*

[LCD](#)

[Locate](#)

[Display](#)

[Cursor](#)

## 6.70. Log

*Description:*

Calculates Natural Logarithm (base e).

*Syntax:*

```
var=Log(numeric expression)
```

*Remarks:*

`var` receives a Natural Logarithm of `numeric expression`  
`numeric expression` must be positive

*Example:*

```
Dim n As Float
```

```
Dim w As Word
```

```
w=12345
```

```
n=Log(w) 'n=9.421006E+01
```

*Related topics:*

[Exp](#)

[Log10](#)

[Pow](#)

## 6.71. Log10

*Description:*

Calculates base 10 Logarithm.

*Syntax:*

```
var=Log10(numeric expression)
```

*Remarks:*

`var` receives a Log10 of `numeric expression`  
`numeric expression`

*Example:*

```
Dim n As Byte
```

```
Dim w As Word
```

```
w=12345
```

```
n=Log10(w) 'n=4.09149E+01
```

*Related topics:*

[Exp](#)

[Log](#)

[Pow](#)

## 6.72. Lookup

[Look at Dim](#)

## 6.73. Loop

[Do](#)

## 6.74. MakeWord

*Description:*

Makes Word or Integer from two bytes.

*Syntax:*

```
MakeWord(var1, var2)
```

var1 MSB byte

var2 LSB byte

*Remarks:*

Very suitable for copying a portion of SRAM.

*Example:*

```
Dim n As Byte
```

```
Dim m As Byte
```

```
Dim w As Word
```

```
n=&h12
```

```
m=&h34
```

```
w=MakeWord(n, m) ' w=&h1234
```

*Related topics:*

[Msb](#)

## 6.75. MemLoad

*Description:*

Quickly loads some SRAM locations.

*Syntax:*

```
MemLoad (var, const1, const1,...)
```

var SRAM will be loaded from var on.

constx constants to load with.

*Remarks:*

Very suitable for initializing variables in SRAM.

*Example:*

```
MemLoad (VarPtr(n), 4, 4, 4, 15, &hff, &hff)
```

```
MemLoad (&h90, "String constants also!", "Test")
```

*Related topics:*

[MemCopy](#)

## 6.76. MemCopy

### Description:

Quick SRAM block copy from Source locations to Destination.

### Syntax:

```
MemCopy (var1, var2, var3)
```

var1 number of bytes to copy

var2 we will copy from here - Source

var3 to here - Destination

### Remarks:

Very suitable for copying a portion of SRAM.

Var2 and Var3 MUST be address (note that Strings "value" are already Addresses)!

### Example:

```
MemCopy(12, VarPtr(Buff1), VarPtr(Buff2))      ' copies 12 Bytes from Buff1 to
Buff2
```

### Related topics:

[MemLoad](#)

## 6.77. Mid

### Description:

Return a specified number of characters in a string.

### Syntax:

```
var=Mid(var1, n1, n2)
```

### Remarks:

var string that Mid chars are assigned.

var1 source string (MUST be string var, not string constant).

n1 starting position of characters from left.

n2 number of characters.

### Example:

```
Dim Name As String*15
Dim Part As String*10
```

```
Name="Mona Lisa"
Part=Mid(Name, 2, 5)   'Part="ona L"
```

### Related topics:

[Right](#)

[Left](#)

## 6.78. MSB

*Description:*

Returns the most significant byte of the Word var.

*Syntax:*

```
var=Msb(var1)
```

*Remarks:*

var byte variable that is assigned.

var1 word variable.

*Example:*

```
Dim n As Byte
Dim x As Word
```

```
n=x      'n holds Lsb byte of x
n=Msb(x) 'n holds Msb byte of x
```

*Related topics:*

[MakeWord](#)

## 6.79. Next

[For](#)

## 6.80. Nokey()

[Key\(\)](#)

## 6.81. Nop

*Description:*

Generates one or more Nop assembler statements.

*Syntax:*

```
Nop[n]
```

*Remarks:*

n optional numeric for more Nops

Usefull for very short delays. Nop takes 1/Q seconds.

*Example:*

```
Nop      ' generates 1 Nop
Nop 5    ' generates 5 Nops
```

## 6.82. On x GoTo

### *Description:*

Jumps to one of listed Labels or executes one of listed Subs, depending on value x.

### *Syntax:*

```
On x GoTo Label0, Label1, Label2.....  
On x Sub0(), Sub1(), Sub2() ....
```

### *Remarks:*

X is a test variable or expression.

LabelN labels to jump to.

SubN subs to call.

### *Example 1:*

```
On n GoTo Test, Lab1, Label3  
Back:  
.  
.  
.  
End  
  
Test:  
  DoTest()  
  GoTo Back  
  
Lab1:  
  DoSomething()  
  GoTo Back  
  
Label3:  
  DoOther()  
  GoTo Back
```

### *Example 2:*

```
On n Test(), Lab1(), Label3()  
.  
.  
.  
End  
  
Sub Test()  
  DoTest()  
End Sub  
  
Sub Lab1()  
  DoSomething()  
End Sub  
  
Sub Label3()  
  DoOther()  
End Sub
```

### *Related topics:*

[Select](#)

## 6.83. Open COM

### Description:

Opens up to four software UART channels.

### Syntax:

```
Open Com=PORT.pin, speed [, Inv] For Input|Output As #n
```

### Remarks:

speed is the baud rate

n is Com number from 1 to 4

Inv option for inverted signal

Interrupts must be disabled during transmitting or receiving through this software routine!

### Example:

```
Open Com=PORTD.0, 9600 For Input As #1
Open Com=PORTD.1, 9600 For Output As #1
Open Com=PORTD.2, 19200, Inv For Output As #2
```

```
Do
  InputBin #1, a, 3 ' input three bytes thru Com1
  Print #1, a; b; c ' print vars on Com1
  Print #2, "test" ' print inverted string constant on Com2
Loop
```

## 6.84. PcKey()

### Description:

Returns a scan code of pressed key on standard AT-PC keyboard.

### Syntax

```
var=PcKey()
```

### Remarks:

var contains the scan code of pressed key

Connected AT-PC keyboard works with Scan Code Set 3, so only one byte (make) is received! (default mode for keyboard when connected to PC is Scan Code Set 2)

See file PCcode.pdf!

Note: PcKey function will pool CLOCK line until a scan code will be transmitted! This call can be used in External interrupt routine if this is not acceptable (because some tasks in main loop must be processed).

### Example:

```
PcKeySend(&hf9) ' turn autorepeat off
a=PcKey()
```

### Related topics:

[PcKeySend\(\)](#)

## 6.85. PcKeySend()

### Description:

Send a command or data to standard AT-PC keyboard.

### Syntax

```
PcKeySend(const)
```

### Remarks:

const is a valid command or data

Connected AT-PC keyboard works with Scan Code Set 3, so, only one byte (make) is received! (default mode for keyboard is Scan Code Set 2)

See file PCcode.pdf!

### Scan codes select:

This two-byte command selects the scan code set. Scan code set 2 is selected by default after a reset. However, scan code set 3 is selected by PCkey() init routine since set 3 is recommended for microcontroller applications.

Command: &hf0

Command: &b000000xx

01: scan code set 1

10: scan code set 2

11: scan code set 3

### Set all keys:

This commands assign attributes to the keys, as follows:

Command: &hf7 all keys have the repeat function (default is no repeat)

Command: &hf8 all keys produce Make and Break codes

Command: &hf9 all keys produce only a Make code (no repeat)

Command: &hfa all keys have the repeat function and produce Make and Break code

This two-byte command controls the behavior of the LEDs.

Command: &hED

Command: &b00000xxx

Bit 0: Scroll lock

Bit 1: Num lock

Bit 2: Caps lock

Reset Command: &hff

### Set Spermatic Rate/Delay:

Command: &hf3

Command: &b0xxxxxx

Bit6	Bit5	Delay
0	0	150ms
0	1	500ms
1	0	750ms
1	1	1 s

Bit4	Bit3	Bit2	Bit1	Bit0	Autorepeat
0	0	0	0	0	30hz
0	1	1	1	1	8hz
1	1	1	1	1	2hz

### Example:

**PcKey()**

*See also:*  
[PcKey\(\)](#)

## 6.86. Peek

*Description:*  
Reads a byte from internal or external SRAM.

*Syntax:*  
`var=Peek (var1)`

*Remarks:*  
`var` The string that is assigned.  
`var1` The address to read the value from.

*Example:*  
`Adr=&h70`  
`n=Peek (Adr)            ' read value from SRAM address &h70`

*Related topics:*  
[Poke](#)  
[Cpeek](#)

## 6.87. Poke

*Description:*  
Writes a byte to internal or external SRAM.

*Syntax:*  
`Poke (var1, var2)`

*Remarks:*  
`var1` The address in internal or external SRAM.  
`var2` The value to be placed in SRAM.

*Example:*  
`Adr=&h70`  
`Poke (Adr, 5)        ' write 5 to SRAM address &h70`

*Related topics:*  
[Peek](#)  
[Cpeek](#)

## 6.88. Pow

### Description:

Returns the Power of its argument.

### Syntax:

```
var=Pow(numeric expression, exponent)
```

### Remarks:

```
var type Float receives a Power of numeric expression
numeric expression any numeric type
exponent any numeric type
```

### Example:

```
Dim n As Byte
Dim f1 As Float, f2 As Float

f2=5.24
n=7

f1=Pow(f2, n)      'f1=1.084723E+05
```

### Related topics:

[Exp](#)

[Log](#)

[Log10](#)

## 6.89. PowerModes

### Description:

Forces processor into one of Power Saving Mode.

Sleep modes enable the application to shut down unused modules in the MCU, thereby saving power. The AVR provides various sleep modes allowing the user to tailor the power consumption to the application's requirements.

Note that not all PowerModes are available in each AVR device! Check datasheets!

### Syntax:

```
Idle
PowerDown
PowerSave
Standby
ExtStandby
```

### Remarks:

**Idle** CPU sleeps after this statement, but the Timers, Watchdog and Interrupt system continue to operate. This power-saving mode is terminated with reset or when an interrupt is received.

**PowerDown** CPU draws only a few micro amperes because the external oscillator is stopped. Only an external reset, a watchdog reset, an external level interrupt or a pin change interrupt can wake up the CPU.

`PowerSave` This mode is identical to `PowerDown` but the CPU can be also be awakened with `Timer2`.

`Standby` This mode is identical to `Power-down` with the exception that the Oscillator is kept running. From `Standby` mode, the device wakes up in six clock cycles.

`ExtStandby` This mode is identical to `Power-save` mode with the exception that the Oscillator is kept running. From `Extended Standby` mode, the device wakes up in six clock cycles..

*Example:*

```
PowerDown
```

## 6.90. Print

*Description:*

Send a variable or constant to the RS-232 port.

*Syntax:*

```
Print var1; var2; ....
Print2 var1; var2; .... ' for second UART
```

*Remarks:*

`var1` variable or constant to print  
`var2` variable or constant to print

You can use a semicolon ; to print more than one variable on a line.  
 When you end a line with a semicolon, no linefeed will be added.

With the built-in terminal emulator, you can easily monitor print statements.

If `$LeadChar` is defined then result will be right justified with Leading Chars as defined. Also, if `Format()` is defined then optional decimal point will be inserted!

*Example:*

```
Dim n As Byte, x As Word
Dim s As String*5
```

```
n=65: w=1234: s="Test"
```

```
Print n
Print w
Print s
Print n; w
Print "n="; n; "w="; w
Print Bcd(n)
Print Hex(w)
Print Chr(n)
```

```
Print2 n
```

```
End
```

*Related topics:*

[Input](#)  
[PrintBin](#)  
[InputBin](#)

## 6.91. PrintBin

### Description:

Sends a binary value(s) to the serial port.

### Syntax:

```
PrintBin var1; var2;...
PrintBin var, n
```

```
PrintBin2 var1; var2;... ' for second UART
```

### Remarks:

var, var1, var2 byte or word sent to the serial port

n number of bytes to send from var up! With this statement you can send the whole SRAM byte by byte!

The number of bytes to send depends on the variable you use, 1 for byte, 2 for word.

### Example:

```
Dim a As Byte, w As Word
```

```
a=5: w=&h3f12
```

```
PrintBin a; w ' three bytes will be sent
PrintBin a, 12 ' 12 bytes will be sent (from a up)
```

```
PrintBin2 a; w ' three bytes will be sent
```

### Related topics:

[InputBin](#)

## 6.92. Pulse

### Description:

Generates a pulse on the specified AVR port pin.

### Syntax:

```
Pulse Port.pin, 0|1, var
```

### Remarks:

0 pulse from 1 to 0 and back to 1

1 pulse from 0 to 1 and back to 0

var defines pulse length according to formula:  $t=(3*var+8)/\text{clock}$

For clock 8MHz and var=1 pulse will be 1.375us.

AVR port pin must first be configured as output.

*Example:*

```
Pulse PortB.2, 1, 10    'pulse pin high for 10.3us
                        'then return to low
```

*Related topics:*[Set](#)[Reset](#)[toggle](#)**6.93. RadToDeg***Description:*

Converts from Radians to Deegrees.

*Syntax:*

```
var=RadToDeg(var1)
```

*Remarks:*

var The var that is assigned Deegrees.

var1 The Radians to convert.

*Example:*

```
Dim n As Byte
Dim f1 As Float, f2 As Float
```

```
f1=3.14159265
f2=RadToDeg(f1)    ' f2=180
```

*Related topics:*[DegToRad](#)[\\$Angles](#)**6.94. RC5***Description:*

Receives the Philips RC5 standard remote IR code.

*Syntax:*

```
Rc5(sysadr, command)
```

*Remarks:*

sysadr is a RC5 family address (Byte)

command is the code of the pressed key (Byte)

Sysadr and Command vars must be declared with Dim first!

TOGGLE BIT is sysadr.5

Command is six bits long, sysadr is five bits!

In case of bad reception RC5 returns 255 in Command, garbage in sysadr!

ATTENTION!

Timer0 and OVF0 interrupt are used. User can NOT use this timer and interrupt for other purposes!  
User MUST enable global interrupts and Ovf0 interrupt!

*Example:*

```
Dim Adr As Byte
Dim Com As Byte

Enable Interrupts 'user must enable interrupts
Enable Ovf0       'user must enable Timer0 overflow interrupt

Do
    RC5(Adr, Com)
    Print Adr; " "; Com
Loop
```

*Related topics:*

[\\$RC5](#)

## 6.95. Randomize

*Description:*

Initialize Rnd generator

*Syntax:*

```
Randomize (seed)
```

*Remarks:*

seed is initial value for random generator, (numeric constant 0-255).

[Rnd](#)

## 6.96. ReadEE

*Description:*

Returns a value from internal EEPROM..

*Syntax:*

```
var=ReadEE (adr)
```

*Remarks:*

var holds a value previously stored in EEPROM at address adr.

*Example:*

```
WriteEE(i, i) ' with counter (omit loc 0)
n=ReadEE(i)
```

*Related topics:*

[WriteEE\(\)](#)

[InitEE](#)

## 6.97. Reset

### Description:

Resets the Bit variable, variable.bit, Port.pin, WatchDog timer or External interrupts flags.

### Syntax:

```
Reset BitVar
Reset Var.bit
Reset PORT.pin
Reset WatchDog
Reset Intx
```

### Remarks:

Port pin must first be configured as an output.

### Example:

```
Reset b          'b is Bit var
RESet n.2       'n is byte var

$Def Led=PORTB.3
Set DDRB.2      'configured for output

Reset PORTB.2   'PortB=0
Reset Led

Set PORTb.2
Set Led

Reset WatchDog 'resets WatchDog

Reset Int0      'resets Int0 flag
```

### Related topics:

[Set](#)  
[Toggle](#)

## 6.98. Return

### Description:

Defines from Function returned value.

### Syntax:

```
Return numeric expression
```

### Remarks:

Return is from Function returned value (Byte, Integer, Word or Long)

### Example:

```
Declare Function Mul(a As Byte, b As Byte) As Byte
Dim n As Byte

n=Mul(5, 7)      'n=35

'////////////////////////////////////
```

```
Function Mul(a As Byte, b As Byte) As Byte
```

```
Return a*b
```

```
End Function
```

*Related topics:*

[Declare](#)

[Function](#)

[Sub](#)

## 6.99. Right

*Description:*

Return the rightmost n characters in a string.

*Syntax:*

```
var=Right(var1, n)
```

*Remarks:*

var string that right chars are assigned.

var1 source string (MUST be string var, not string constant).

n number of characters from the right.

*Example:*

```
Dim Name As String*15
```

```
Dim Part As String*10
```

```
Name="Mona Lisa"
```

```
Part=Right(Name, 4) 'Part="Lisa"
```

*Related topics:*

[Left](#)

[Mid](#)

## 6.100. Rnd

*Description:*

Returns a pseudo random number between 0 and 255 (type Byte).

*Syntax:*

```
var=Rnd()
```

*Remarks:*

var variable that receives the random number

*Example:*

```
Randomize(5) 'initialize Rnd generator
```

```
n=Rnd()
```

*Related topics:*

[Randomize](#)

## 6.101. Rotate

*Description:*

Rotate variable left or right n number of places.

*Syntax:*

```
Rotate(left|right, var1, var2)
var3=Rotate(left|right, var1, var2)
```

*Remarks:*

var1 is number of places to rotate

var2 is actual variable to be rotated

var3 is var to which rotated var2 is assigned

*Example:*

```
Rotate (Right, 1, n)   'rotates var n right one place
m=Rotate (Left, 4, n)  'rotates var n left four places and assign it to var m
```

*Related topics:*

[Shift](#)

## 6.102. Select

*Description:*

Selects a block of statements from a list, based on the value of an expression.

*Syntax:*

```
Select Case var
  Case val1
    statements
  Case val2 To val3
    statements
  Case <val4
    statements
  Case val5, val6, val7
    statements
  Case Else
    statements
End Select
```

*Remarks:*

var is a test variable (Byte, Integer or Word).

val1, val2, ... are different possible variable values.

If one "Case" matches, no subsequent "Cases" will be tested !

**The code length under one Case is limited to 64 words!**

*Example1:*

```
Select Case n
  Case 32
    Print "SPACE"
  Case 13
    Print "ENTER"
  Case 65
    Print "A"
  Case 49
    Print "1"
  Case 50
    Print "2"
  Case 120
    Print "X"
  Case Else
    Print "Miss!"
End Select
```

*Example2:*

```
Dim s As String*1
Select Case s
  Case "a", "A"           ' a or A
    Print "This is a or A"
  Case "b", "c", "d"     ' b, c or d
    Print "others"
  Case Else
    Print "Miss!"
End Select
```

*Related topics:*

If

## 6.103. Set

*Description:*

Sets the Bit variable, variable.bit or Port.pin.

*Syntax:*

```
Set BitVar
Set Var.bit
Set PORT.pin
```

*Remarks:*

Port pin must first be configured as an output.

*Example:*

```
Set b           'b is Bit var
Set n.2        'n is byte var
```

```

Set DDRB.2      'PORTB.2 is output
Set PORTB.2    'PORTB.2=1
Set Led        'sets PORT.bit defined as LED

Reset PORTB.2  'PORTB.2=0
Reset Led      'resets PORT.bit defined as LED

```

*Related topics:*

[toggle](#)

[Reset](#)

## 6.104. Shift

*Description:*

Shift var left or right n number of places.

*Syntax:*

```

Shift(left|right, var1, var2)
var3=Shift(left|right, var1, var2)

```

*Remarks:*

var1 is number of places to shift

var2 is actual variable to be shifted

var3 is var to which shifted var2 is assigned

*Example:*

```

Shift(Right, 1, n)    'shift var n right one place
m=Shift(Left, 4, n)  'shift var n left four places and assign it to var m

```

*Related topics:*

[Rotate](#)

## 6.105. ShiftOut

*Description:*

ShiftOut variable(s) on a PORTx.pin, usually to fill shift registers.

*Syntax:*

```

ShiftOut var1; var2;....
ShiftOut var1, n

```

var1, var2 vars to be shifted out on port.pin defined by \$ShiftOut

n number of bytes to shift out

*Remarks:*

Very suitable for expanding output ports by adding shift registers like 74HC4094, TIC 2965 etc.

*Example:*

```
ShiftOut n, 10    'ShiftOut the whole array
ShiftOut i; w    'ShiftOut i and w
```

*Related topics:*[\\$ShiftOut](#)[ShiftIn](#)**6.106. ShiftIn***Description:*

Shift IN variable on a Pinx.pin.

*Syntax:*

```
ShiftIn var1
```

var var to be shifted into from PINx.pin defined by \$ShiftOut data

*Example:*

```
n=ShiftIn    'Load n from outhier shift register
```

*Related topics:*[\\$ShiftOut](#)[ShiftOut](#)**6.107. Sin***Description:*

Returns the trigonometric sine of its argument.

*Syntax:*

```
var=Sin(numeric expression)
```

*Remarks:*

var type Float receives a Sine of numeric expression  
 numeric expression can be in Radians or Deegrees, depending on \$Angles metastatement!

*Example:*

```
Dim n As Byte
Dim f1 As Float
```

```
n=30          ' assuming $Angles=Degrees
f1=Sin(n)     ' f1=0.5000000
```

*Related topics:*[Cos](#)

[Tan](#)  
[Asin](#)  
[Acos](#)  
[Atan](#)

## 6.108. Sinh

*Description:*

Returns the Sine Hiperbolicus of its argument.

*Syntax:*

```
var=Sinh(numeric expression)
```

*Remarks:*

var type Float receives a Sinh of numeric expression  
numeric expression

*Example:*

```
Dim f1 As Float
```

```
f1=Sinh(5)      'f1=74.20995
```

*Related topics:*

[Cosh](#)  
[Tanh](#)

## 6.109. Sort

*Description:*

Sorts values in SRAM buffer.

*Syntax:*

```
Sort(SRAMbuff, length)
```

*Remarks:*

SRAMbuff is name of Buffer in SRAM (starting address in SRAM)  
length is number of bytes to Sort

*Example:*

```
Dim DB(16) As Byte
```

```
Sort(DB, 16)      'sorts 16 bytes in array DB
```

## 6.110. Sound

*Description:*

Makes a sound.

*Syntax:*

Sound var1, var2

var1 \* 10 is half of period in us,  $f = 1/(10 * var1 * 2)$  (frequency in Hz)

var2 \* 10 is number of periods in sound (duration)

*Example:*

```
Sound 50, 100    '1 kHz beep, 1 sec in duration
Sound 25, 100    '2 kHz beep, 0.5 sec in duration
```

*Related topics:*

[\\$Sound](#)

## 6.111. SpiIn

*Description:*

Receives a value from the SPI-bus in SLAVE mode.

*Syntax:*

```
var = SpiIn
var variable to receive data from the SPI bus
```

*Remarks:*

SS pin is input and must be driven by MASTER!

*Example:*

```
n=SpiIn
```

*Related topics:*

[SPIOut](#)

## 6.112. SpiOut

*Description:*

Sends the value of a variable to the SPI-bus in MASTER mode.

*Syntax:*

```
SpiOut var
SpiOut var1; var2;....,wait
SpiOut var1, n, wait
```

var, var1, var2 variables to be shifted out

n number of bytes from SRAM to send via SPI bus, starting with var1

**Remarks:**

SS pin is set to OutPut (user can use this pin to select SLAVE)!

**Example:**

```
SpiOut i           'ShiftOut i (9)
SpiOut n; 10, Wait 'ShiftOut the whole array
```

**Related topics:**

[SPIn](#)

## 6.113. Sqr

**Description:**

Calculates Float Square of its argument.

**Syntax:**

```
var=Sqr(numeric expression)
```

**Remarks:**

var **Float**, receives a **Square of** numeric expression  
numeric expression

**Example:**

```
Dim f1 As Float
Dim f2 As Float

f1=12.345
f2=Sqr(f1) ' f2=f1*f1=152.399
```

**Related topics:**

[Pow](#)

[Sqrt](#)

## 6.114. Sqrt

**Description:**

Calculates Square root.

**Syntax:**

```
var=Sqr(numeric expression)
```

**Remarks:**

var **receives a Square root of** numeric expression  
numeric expression **must be positive**

**Example:**

```
Dim n As Byte
Dim w As Word
```

```
w=12345
n=Sqrt(w) 'n=111
```

## 6.115. Start

### Description:

Starts or enables one of the specified devices.

### Syntax:

```
Start device
Start Adc [, Vref=Ext|Int|Vcc]
```

### Remarks:

device can be:

- Adc supply for AD converter (default is stopped), user can specify type of used Vref!
- Ac supply for analog comparator (default is started)
- WatchDog
- Timer0, Timer1, Timer2

### Example:

```
Start Ac           ' switch supply to Ac
Start Adc, Vref=Int ' switch supply to Adc, Internal (2.56V) Vref is used
Start WatchDog     ' enables WatchDog
Start Timer1       ' start Timer1
```

### Related topics:

[Stop](#)

## 6.116. Stop

### Description:

Stops or disables one of the specified devices.

### Syntax:

```
Stop device
```

### Remarks:

device can be:

- Adc supply for AD converter (default is stopped)
- Ac supply for analog comparator (default is started)
- WatchDog
- Timer0, Timer1, Timer2

### Example:

```
Stop Ac           ' switch supply from Ac
Stop Adc          ' switch supply from Adc
Stop WatchDog    ' disables WatchDog
Stop Timer1      ' stops Timer1
```

*Related topics:*

[Start](#)

## 6.117. Str

*Description:*

Converts a number to a string.

*Syntax:*

```
var=Str(numeric expression)
```

*Remarks:*

var string variable

If `$LeadChar` is defined then result will be right justified with Leading Char as defined. Also, if `Format ()` is defined then optional decimal point will be inserted!

*Example:*

```
Dim n As Byte
Dim s As String*5

n=123
s=Str(n)   's="123"
```

*Related topics:*

[Val](#)

## 6.118. Sub

*Description:*

Defines a subroutine procedure.

*Syntax:*

```
Sub NameOfSub(parameters list)
```

*Remarks:*

NameOfSub is the name of the subroutine  
parameters list is the name and type of parameters, comma delimited (can not be Bit)

Sub must first be declared using the Declare keyword (names of passing parameters must be the same as later in Sub).

*Example:*

```

Declare Sub Test(a As Byte, b As Byte) 'declares a Sub Test

Test(2, 6)      '22 will be Printed

End

'////////////////////////////////////
Sub Test(a As Byte, b As Byte)
Local d As Byte ' local var is declared

d=10
[Exit Sub] ' optionally exit from Sub

Print a*b+d
End Sub      ' here is end of Sub

```

**Related topics:**

Declare  
Function

**6.119. Swap***Description:*

Swaps variable(s), depending on type of variable.

*Syntax:*

```

Swap(var)
Swap(var1, var2)

```

*Remarks:*

var if var is `Byte` then nibles will be swaped, if var is `Word` or `Integer` then bytes will be swaped.  
var1 this variable will be swaped with var2

*Example:*

```

Dim a As Byte, b As Byte
Dim w As Word

a=&h25
b=&h34
Swap(a)      ' a=&h52

w=&h1234
Swap(w)      ' w=&h3412

Swap(a, b)   ' a=&h34, b=&h25

```

## 6.120. Tan

*Description:*

Returns the trigonometric Tangent of its argument.

*Syntax:*

```
var=Tan(numeric expression)
```

*Remarks:*

var type Float receives a Tangent of numeric expression  
numeric expression can be in Radians or Deegrees, depending on \$Angles metastatement!

*Example:*

```
Dim n As Byte
Dim f1 As Float

n=30          ' assuming $Angles=Degrees
f1=Tan(n)    ' f1=0.5773503
```

*Related topics:*

[Sin](#)

[Cos](#)

[Asin](#)

[Acos](#)

[Atan](#)

## 6.121. Tanh

*Description:*

Returns the Tangent Hiperbolicus of its argument.

*Syntax:*

```
var=Tanh(numeric expression)
```

*Remarks:*

var type Float receives a Tanh of numeric expression  
numeric expression

*Example:*

```
Dim f1 As Float

f1=Tanh(5)    ' f1=0.999909
```

*Related topics:*

[Sinh](#)

[Cosh](#)

## 6.122. Toggle

*Description:*

Toggles the state of an AVR port pin.

*Syntax:*

```
Toggle PORT.pin
```

*Remarks:*

AVR port pin must first be configured as an output.

*Example:*

```
Toggle PORTB.2      'toggles PortB.2
Toggle Led          'toggles Port.Pin named Led (defined using $Def)
```

*Related topics:*

[Set](#)

[Reset](#)

## 6.123. UCase

*Description:*

Returns an all-uppercase version of its string argument.

*Syntax:*

```
var=UCase(var1)
```

*Remarks:*

var uppercase string version of var1  
var1 original string variable.

*Example:*

```
Dim Name As String*15
Dim Part As String*10

Name="Mona Lisa"
Part=UCase(Name)      'Part="MONA LISA"
```

*Related topics:*

[LCase](#)

## 6.124. Val

*Description:*

Returns the numeric equivalent of a string.

*Syntax:*

```
var=Val(string)
```

*Remarks:*

var variable to store the string value.  
string string variable

*Example:*

```
Dim s As String * 8
Dim n As Byte

s="123"      'init string
n=Val(s)    'n=123
```

*Related topics:*

[Str](#)

## 6.125. VarPtr

*Description:*

Returns the SRAM or XRAM address of a variable (pointer).

*Syntax:*

```
var1=VarPtr(var2)
```

*Remarks:*

var1 variable that will pointing to var2.  
var2 variable to retrieve the address from.

Var1 must be declared as `Word` for devices with more than 256 bytes of SRAM!

*Example:*

```
Dim n As Byte           'global byte variable named a
Dim w As Word           'global word variable named w
Dim f As Float          'global word variable named w
Dim db(10) As Byte      'global array of ten bytes named n
Dim s1 As String * 8    'global string variable named s1, length must be specified

adr=VarPtr(n)           'adr=&h60
adr=VarPtr(w)           'adr=&h61
adr=VarPtr(f)           'adr=&h63
adr=VarPtr(db)          'adr=&h67
adr=VarPtr(s1)          'adr=&h71
```

## 6.126. Wait, Waitms, Waitus

*Description:*

Waits seconds, milliseconds or microseconds\*10.

*Syntax:*

```
Wait var      - waits var seconds
WaitMs var    - waits var milliseconds
```

`WaitUs var` - waits `var` microseconds\*10

*Remarks:*

`var` - Byte var type

`Wait`, `WaitMs` and `WaitUs` are not very precise, especially `WaitUs` at lower values!

All enabled Interrupts are active during Waiting!

*Example:*

```
Wait 2      ' waits 2seconds
WaitMs 25   ' waits 25ms
WaitUs 3    ' wait 30us
```

## 6.127. Wend

### While

## 6.128. While

*Description:*

Executes a series of statements as long as a given condition is True.

*Syntax:*

```
While integer expression
    statements
Exit While      'you can EXIT from the loop at any time
Wend
```

*Remarks:*

condition is a boolean expression that evaluates to True or False.

If condition is True, all statements are executed until the `Wend` statement is encountered. Control then returns to the `While` statement and the condition is checked again. If condition is still True, the process is repeated, otherwise execution resumes with the statement following the `Wend` statement.

*Example:*

```
While i<6      ' for all ADC inputs
    Print Adc8(i)
    Incr i
Wend
```

*Example:*

[Do-Loop](#)

[For-Next](#)

## 6.129. WriteEE

*Description:*

Writes a value into internal EEPROM at location *adr*.

*Syntax:*

```
WriteEE(adr, var [, var1, var2, ...varn])
```

*Remarks:*

*adr* the address in EEPROM that *var* will be stored at. (*adr* can be a constant, variable or expression)

*var* must be variable or const to be stored in EEPROM at address *adr*.

*var1-n* can be expressions or constants to initialize EEPROM starting at address *adr*.(must be Bytes)

*Example:*

[ReadEE](#)

*See also:*

[ReadEE](#)

[InitEE](#)

## Index

<b>1.</b>	<b>INTRODUCTION .....</b>	<b>2</b>
1.1.	Compiler Operating System Compatibility .....	2
1.2.	AVR chip supported .....	3
1.3.	Development Environment .....	4
<b>2.</b>	<b>FASTAVR LANGUAGE REFERENCE .....</b>	<b>5</b>
2.1.	Source code / File Data .....	5
2.2.	Source code - Structure .....	5
2.3.	Statements - multiple per line .....	5
2.4.	Comments .....	6
2.5.	Names - Symbols .....	6
2.6.	Types .....	7
2.6.1.	FastAVR language General .....	7
2.6.2.	Type Conversions .....	7
2.6.3.	Types Arithmetic .....	8
2.6.4.	Assigning Statements .....	9
2.7.	Constants .....	10
2.7.1.	Constants - Scope .....	10
2.7.2.	Constants- Numbers and Their Syntax .....	10
2.7.3.	Constants, Arithmetic - Declaring .....	11
2.7.4.	Constants, Arithmetic Arrays - Declaring .....	11
2.7.5.	Constants, String .....	12
2.7.6.	Constants, String Arrays .....	12
2.8.	Variables .....	13
2.8.1.	Variables - Scope .....	13
2.8.2.	Variables, Arithmetic - Declaring .....	13
2.8.3.	Variables, Arithmetic - Run-time Type Conversions: .....	14
2.8.4.	Variables, Arithmetic - Arrays .....	14
2.8.5.	Variables, String .....	14
2.8.6.	Variables, String Arrays .....	15
2.9.	Declarations - Procedures and Functions .....	16
2.9.1.	Declaring Procedures .....	16
2.9.2.	Declaring Functions .....	17
2.9.3.	Declaring Interrupts .....	18
2.10.	Statements .....	18
2.10.1.	Statements, Arithmetic Expressions .....	18
2.10.2.	Statements, String Expressions .....	19

---

<b>2.11.</b>	<b>Program Flow</b> .....	<b>19</b>
2.11.1.	Statement, Do - Loop.....	19
2.11.2.	Statement, While - When.....	20
2.11.3.	Statement, For - Next.....	20
2.11.4.	Statement - If .....	21
2.11.5.	Statement - Select Case.....	22
2.11.6.	Statement - Goto .....	23
2.11.7.	Statement - On X Goto .....	23
2.11.8.	Statement - On X Sub() .....	24
<b>2.12.</b>	<b>Compiler and Limitations</b> .....	<b>25</b>
<b>2.13.</b>	<b>Language Specific</b> .....	<b>25</b>
<b>2.14.</b>	<b>Interrupts</b> .....	<b>30</b>
<b>2.15.</b>	<b>Outputs</b> .....	<b>33</b>
<b>2.16.</b>	<b>Memory Usage</b> .....	<b>33</b>
<b>2.17.</b>	<b>Assembler Programming</b> .....	<b>34</b>
<b>3.</b>	<b>FASTAVR IDE</b> .....	<b>35</b>
3.1.	Editor .....	35
3.2.	IDE .....	37
3.3.	Keyboard Commands.....	38
3.4.	Mouse Use.....	39
<b>4.</b>	<b>FASTAVR TOOLS</b> .....	<b>40</b>
4.1.	AVR Studio.....	40
4.2.	LCD Character Generator.....	40
4.3.	Terminal Emulator.....	41
4.4.	AVR Calculator .....	42
4.5.	Programmer .....	43
<b>5.</b>	<b>AVR FUNDAMENTS</b> .....	<b>44</b>
<b>6.</b>	<b>FASTAVR KEYWORDS</b> .....	<b>45</b>
6.1.	Meta - Statements .....	45
6.1.1.	Compiler directives.....	45
6.1.1.1.	\$Angles .....	45
6.1.1.2.	\$Asm.....	46
6.1.1.3.	\$Include .....	46

---

6.1.1.4.	\$IncludeAsm.....	46
6.1.1.5.	\$Source .....	47
6.1.2.	Processor Configuration.....	47
6.1.2.1.	\$Baud.....	47
6.1.2.2.	\$Clock.....	48
6.1.2.3.	\$Device .....	48
6.1.2.4.	\$Stack .....	49
6.1.3.	I/O Configuration.....	49
6.1.3.1.	\$Def .....	49
6.1.3.2.	\$1Wire .....	50
6.1.3.3.	\$DTMF .....	50
6.1.3.4.	\$I2C .....	51
6.1.3.5.	\$Key.....	51
6.1.3.6.	\$LeadChar.....	53
6.1.3.7.	\$Lcd .....	53
6.1.3.8.	\$PcKey.....	54
6.1.3.9.	\$RC5.....	55
6.1.3.10.	\$ShiftOut.....	55
6.1.3.11.	\$Sound .....	56
6.1.3.12.	\$Spi .....	56
6.1.3.13.	\$Timer.....	56
6.1.3.14.	\$WatchDog .....	57
<b>6.2.</b>	<b>HD61202, KS0108B and SEP1520 Graphic LCD support .....</b>	<b>58</b>
6.2.1.	General.....	58
6.2.2.	\$GLCD, \$GCtrl .....	59
6.2.3.	Fill.....	59
6.2.4.	FontSet.....	60
6.2.5.	Gcls .....	61
6.2.6.	Glcd .....	61
6.2.7.	GlcdInit.....	61
6.2.8.	GRead .....	62
6.2.9.	GWrite .....	62
6.2.10.	ImgSet.....	63
6.2.11.	Inverse.....	64
6.2.12.	LineH .....	64
6.2.13.	LineV .....	65
6.2.14.	Point.....	65
6.2.15.	Pset.....	65
<b>6.3.</b>	<b>PCD8544 - NOKIA 3310 .....</b>	<b>66</b>
6.3.1.	General.....	66
6.3.2.	\$GLCD .....	67
6.3.3.	Contrast.....	68
6.3.4.	FontSet.....	68
6.3.5.	Glcd .....	69
6.3.6.	Gwrite .....	69
6.3.7.	ImgSet.....	70
6.3.8.	Inverse.....	71
6.3.9.	Gcls .....	71
<b>6.4.</b>	<b>T6963C Graphic LCD support.....</b>	<b>71</b>
6.4.1.	\$GLCD, \$Gctl.....	71
6.4.2.	Box.....	72
6.4.3.	Circle .....	73
6.4.4.	Fill.....	73

---

---

6.4.5.	FontSet.....	74
6.4.6.	Gcls.....	74
6.4.7.	GCommand.....	75
6.4.8.	GCursor.....	75
6.4.9.	General.....	76
6.4.10.	GLcd.....	76
6.4.11.	GlcdInit.....	77
6.4.12.	GRead.....	77
6.4.13.	GrpAreaSet.....	78
6.4.14.	GrpHomeSet.....	78
6.4.15.	GWrite.....	79
6.4.16.	ImgSet.....	79
6.4.17.	Inverse.....	80
6.4.18.	Line.....	81
6.4.19.	LineH.....	81
6.4.20.	LineV.....	82
6.4.21.	Point.....	82
6.4.22.	Pset.....	83
6.4.23.	Tcls.....	83
6.4.24.	TLcd.....	83
6.4.25.	TxtAreaSet.....	84
6.4.26.	TxtHomeSet.....	84
<b>6.5.</b>	<b>1WWrite.....</b>	<b>85</b>
<b>6.6.</b>	<b>1WReset.....</b>	<b>85</b>
<b>6.7.</b>	<b>1WRead.....</b>	<b>86</b>
<b>6.8.</b>	<b>Abs.....</b>	<b>87</b>
<b>6.9.</b>	<b>Ac.....</b>	<b>87</b>
<b>6.10.</b>	<b>Acos.....</b>	<b>87</b>
<b>6.11.</b>	<b>Adc.....</b>	<b>88</b>
<b>6.12.</b>	<b>Asc.....</b>	<b>88</b>
<b>6.13.</b>	<b>Asin.....</b>	<b>89</b>
<b>6.14.</b>	<b>Atan.....</b>	<b>90</b>
<b>6.15.</b>	<b>Atan2.....</b>	<b>90</b>
<b>6.16.</b>	<b>Baud.....</b>	<b>91</b>
<b>6.17.</b>	<b>Bcd.....</b>	<b>92</b>
<b>6.18.</b>	<b>BitWait.....</b>	<b>92</b>
<b>6.19.</b>	<b>Case.....</b>	<b>93</b>
<b>6.20.</b>	<b>Chr.....</b>	<b>93</b>
<b>6.21.</b>	<b>Const.....</b>	<b>93</b>

---

---

6.22.	Cls.....	94
6.23.	Cos.....	94
6.24.	Cosh.....	95
6.25.	CPeek .....	95
6.26.	Cre8.....	95
6.27.	Cursor .....	96
6.28.	Data .....	96
6.29.	Declare .....	96
6.30.	Decr .....	97
6.31.	DefLcdChar.....	97
6.32.	Dim.....	98
6.33.	Disable.....	99
6.34.	Display .....	100
6.35.	DegToRad.....	100
6.36.	Do .....	101
6.37.	DTMF.....	101
6.38.	Enable .....	102
6.39.	End .....	103
6.40.	Exit .....	103
6.41.	Exp .....	103
6.42.	Find8 .....	104
6.43.	Find16 .....	104
6.44.	For .....	105
6.45.	Format .....	105
6.46.	Fract.....	106
6.47.	FromBcd .....	107
6.48.	Function.....	107
6.49.	GoTo .....	108

---

---

6.50.	I2CRead .....	108
6.51.	I2CStart .....	108
6.52.	I2CStop .....	110
6.53.	I2CWrite .....	110
6.54.	If .....	110
6.55.	Incr .....	111
6.56.	InitLcd .....	111
6.57.	InitEE .....	112
6.58.	Input .....	112
6.59.	InputBin .....	113
6.60.	Int .....	113
6.61.	IntX .....	114
6.62.	Instr .....	114
6.63.	Key() .....	115
6.64.	LCase .....	115
6.65.	Lcd .....	116
6.66.	Left .....	116
6.67.	Len .....	117
6.68.	Local .....	117
6.69.	Locate .....	118
6.70.	Log .....	118
6.71.	Log10 .....	119
6.72.	Lookup .....	119
6.73.	Loop .....	119
6.74.	MakeWord .....	120
6.75.	MemLoad .....	120
6.76.	MemCopy .....	121
6.77.	Mid .....	121

---

---

6.78.	MSB.....	122
6.79.	Next .....	122
6.80.	Nokey().....	122
6.81.	Nop .....	122
6.82.	On x GoTo .....	123
6.83.	Open COM .....	124
6.84.	PcKey().....	124
6.85.	PcKeySend() .....	125
6.86.	Peek .....	126
6.87.	Poke.....	126
6.88.	Pow .....	127
6.89.	PowerModes .....	127
6.90.	Print .....	128
6.91.	PrintBin .....	129
6.92.	Pulse .....	129
6.93.	RadToDeg.....	130
6.94.	RC5 .....	130
6.95.	Randomize .....	131
6.96.	ReadEE .....	131
6.97.	Reset.....	132
6.98.	Return .....	132
6.99.	Right.....	133
6.100.	Rnd.....	133
6.101.	Rotate.....	134
6.102.	Select .....	134
6.103.	Set.....	135
6.104.	Shift.....	136
6.105.	ShiftOut .....	136

---

---

6.106.	ShiftIn .....	137
6.107.	Sin.....	137
6.108.	Sinh .....	138
6.109.	Sort.....	138
6.110.	Sound .....	139
6.111.	SpiIn.....	139
6.112.	SpiOut.....	139
6.113.	Sqr .....	140
6.114.	Sqrt.....	140
6.115.	Start.....	141
6.116.	Stop .....	141
6.117.	Str.....	142
6.118.	Sub.....	142
6.119.	Swap.....	143
6.120.	Tan .....	144
6.121.	Tanh .....	144
6.122.	Toggle.....	145
6.123.	UCase .....	145
6.124.	Val .....	145
6.125.	VarPtr .....	146
6.126.	Wait, Waitms, Waitus .....	146
6.127.	Wend .....	147
6.128.	While .....	147
6.129.	WriteEE.....	148
<b>INDEX.....</b>	<b>.....</b>	<b>149</b>

Notes: